

OPERATING AND INSTALLATION INSTRUCTIONS

INSPIRE 40 INSERT

is exempt for use in smoke control areas when burning dry wood



www.heta.dk



EN

DANISH DESIGN . DANISH QUALITY . DANISH PRODUCTION

Congratulations on your new wood stove insert, we are confident that you will be more than satisfied with your new Heta stove. Especially if you follow the following advice and instructions.

Inspire 40 wood stove insert is approved according to EN 13229, NS 3058 and 3059. These approvals, means that the wood stove insert meets a variety of specifications and requirements, ensuring it is made of quality materials, minimum environmental impact and that it has an optimum fuel economy.

Operating Instructions Contents

Before installation.....	3-4
1. Operating instructions	5
1.1 Before using	5
1.2 First firing.....	5
1.3 Regulating the airflow	5
1.4 Lighting the stove.....	5
1.5 Refueling	5
1.6 Emptying the ash.....	6
1.7 Reduced burning.....	6
1.8 Risk of explosion	7
1.9 Draft conditions in the chimney.....	7
1.10 Fuel.....	7
1.11 Operational problems.....	8
1.12 Chimney fires.....	8
1.13 Troubleshooting	9
1.14 Maintenance.....	10
1.15 Cleaning the glass.....	10
1.16 Maintenance schedule	10
1.17 Cleaning/Replacing bicks after chimney sweeping	11
1.18 Parts	12
1.19 Stove data table EN 13229	13
1.20 Stove data table EN 13240	13
1.21 Garantee.....	13
2. Installation Instructions	14

Heta A/S

Jupitervej 22,
DK-7620 Lemvig

Phone: +45 9663 0600
E-mail: heta@heta.dk

Copyright © 2014
Heta is a registered
trademark of Heta A/S

Printed in Denmark
Subject to printing errors
and changes.

17.06.2024
0037-1475 Version 2,9

BEFORE INSTALLATION

Heta wood stoves are quality products, therefore, your first impression is very important! We have a good logistics network, which transports Heta products with great care for our dealers. Nevertheless, when in transport or handling, damage of the often-heavy stoves can occur. It is important that upon receipt check your Heta product completely and report any damage or defects to your dealer.

The packaging must be disposed of as follows:

Wood is untreated and able to burn in the stove.

Plastic and cardboard you can drop off at your local recycling center.

Unpacking the insert

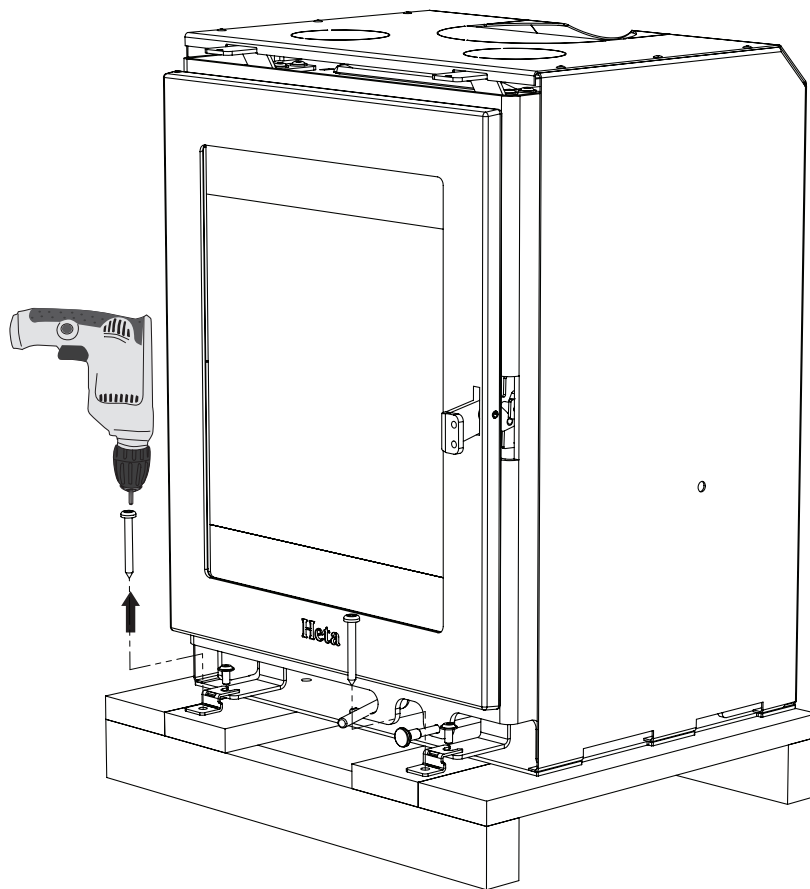

Accessory Parts

When the need for direct external air is required, the following must be purchased:

1511-0030

External air from behind

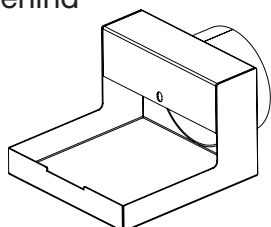



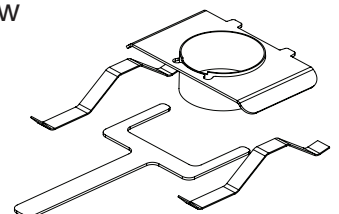

1511-0031

External air from below

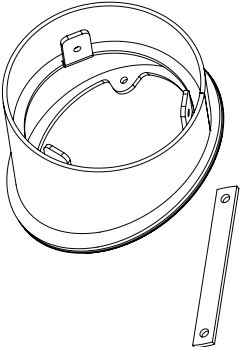

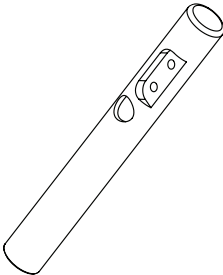
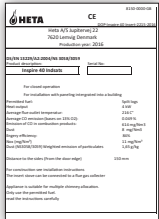
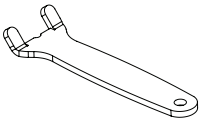
With your new wood stove you should find the following:

<p>Operating / Instruction manual</p>		<p>Flue collar 1525-0029 with mounting tool 1013-0864</p>	
<p>Heta glove Nr. 0023-9002</p>		<p>Door handle 0016-0031</p>	
<p>Data plate</p>		<p>Ash pan handle 1020-0001</p>	
<p>Q.C. check Standard V1,30</p>		<p>4 x M10x20 0008-1210 4 x M6x10 0008-0054 3 x M6x16 0008-1201 2 x M6x25 0008-1115 2 x M5x10 0008-2005</p>	

Required tools are not supplied.

1. OPERATING INSTRUCTIONS

1.1 Before using

Before the wood stove is used make sure required installation conditions, are met. See page 15.

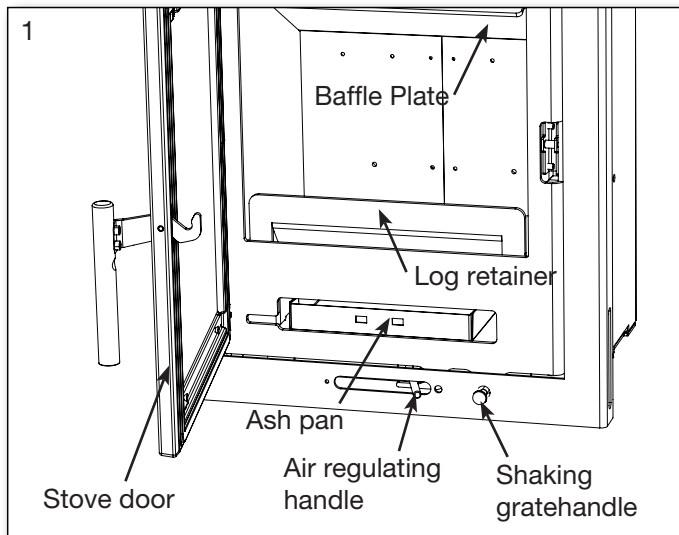

1.2 First firing

The stove paint is fully cured from the factory, but a minor unpleasant odour could still arise.

1.3 Regulating the air flow

A handle below the door regulates the stoves combustion air. This stove is equipped with a start-up air function. When lighting the stove, the handle must be, raised slightly and moved completely to the right. After the fire is established. Return the lever to the operating position. There after adjust the air accordingly.

The Inspire stoves are designed and tested to burn extremely cleanly with very little smoke discharge and are exempt for use in smoke control areas throughout the UK when burning dry wood logs. To comply, a permanent stop is fitted to ensure that the air control slider cannot be closed beyond 41% of its fully open position.

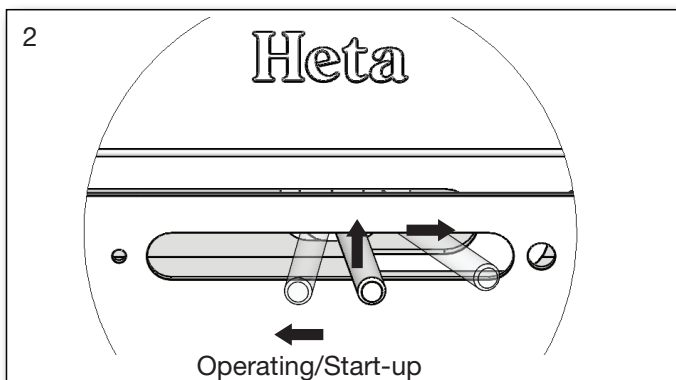

A permanent amount of air will therefore enter the firebox to feed the fire producing negligible amounts of smoke and unburnt hydrocarbons. The appliances will only be considered as an exempt appliances if this stop is in place.

1.4 Lighting the stove

Place two pieces of wood on the bottom. Stack kindling on top in layers with air between. Setting fire starter (bag, brick, paraffin) on the top, now you are ready to light the fuel. The flames must work from the top down.



The use of lighter fluid, oils or any liquid fuels is strictly forbidden from use in a wood stove.

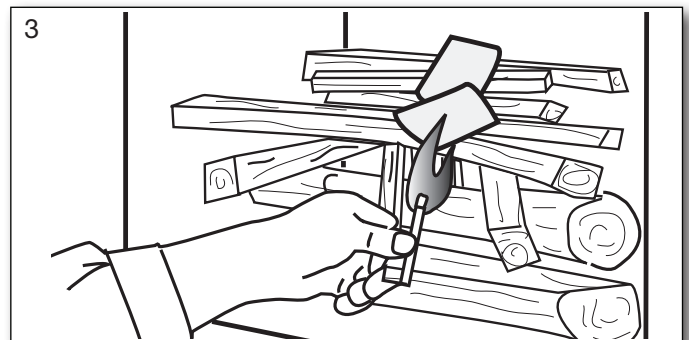

Fully open the combustion air into the start-up air position and the door ajar (about one cm open). Once the fire is established and the chimney is hot (after about ten minutes) closed door and regulate the air into operating position. We recommend, all of the first fuel is burned with the combustion air fully open in the operating position. This ensures the stove and chimney are thoroughly heated.



The stove is safety tested with a load of 1.8 kg of firewood. The guarantee is void if this amount is exceeded.



Startup/Lighting
Scan the code and select a language.

1.5 Refueling

Refueling of your stove should be done while there is still a good layer of embers. Distribute the embers with the majority of them to the front. Place pieces of wood equivalent to about 1 kg on top of the embers perpendicular to the door. Now open the combustion air completely. If the

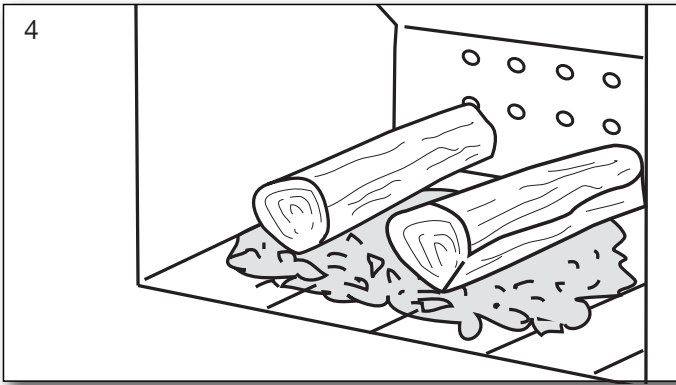

stove and/or chimney cools down too much, it may be necessary to use the start-up air and possibly have the door ajar.

The wood will then ignite within a very short time (Typically 1 to 3 minutes). Once the fuel is ignited. Close the door and regulate the air back to operating air. When the fire is well established, you can now regulate the operating air to the desired combustion level.

Nominal heat out-put is 4 kW, equivalent to the operating air at about 80% open.

Ensure when refueling that the wood is not too close, it will cause poorer combustion, less heat out-put and lower efficiency.

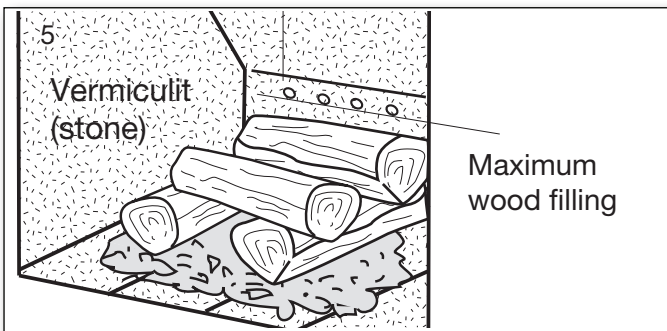

The fuel load, must be maintained below the top series of air holes and within the outer vent in each side. Fig. 5



When refueling be careful to place the fuel into the combustion chamber gently, (use the provided glove). By not doing so you risk cracking or breaking the vermiculite.

If there is reduced draft in the chimney, we recommend opening a window at stoking. This will give better ventilation to the room and more oxygen for combustion.

1.6 Emptying the ash

By using the shaker grate, it rotates back and forth so the ash falls through the holes and into the ashtray, see Fig. 6.

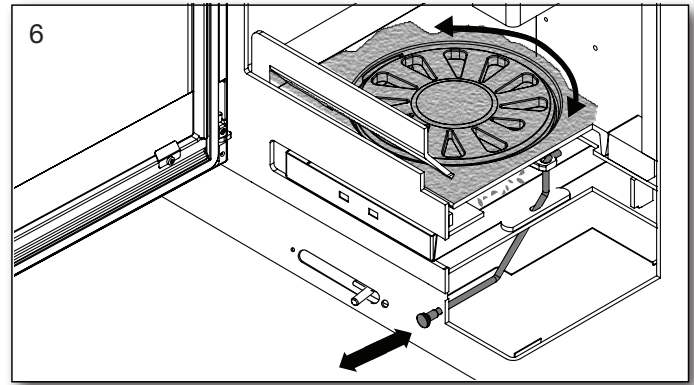

It is advantageous to leave a layer of ash in the bottom of the combustion chamber on top of the grate as insulation. For emptying the ash pan - use the supplied handles 1020-0001 use of the ashtray tool, see Fig. 7.

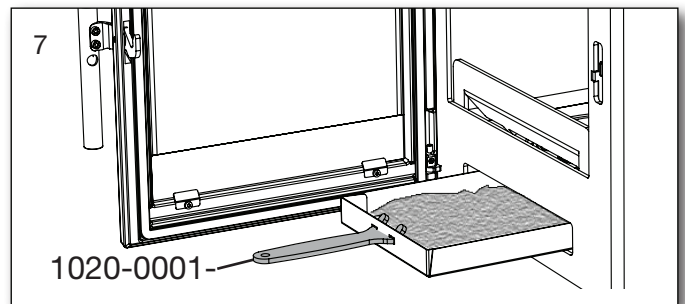

Be careful when emptying the ashes out. There can be hot embers left for a long time.

It is an advantage for the next firing to leave a layer of ash lying in the bottom of the firebox.

1.7 Reduced burning

The stove is, designed for intermittent use.

It is important to maintain the layer of hot embers. Lower heat out-put occurs when no flames come from the tree, when it becomes glowing charcoal.

If you are looking for less heat out-put, achieve this by fueling with smaller volumes of wood and a lower operating air. You may not completely close the operating air during firing.

Be aware that the stove will naturally soot if the operating air is too low. This is not good for the environment. There is also a risk for the glass, the chimney and other parts will become sooted. By a combination of the above and possibly burning damp wood. Can lead to high levels of soot that it becomes sticky. Causing the sealing of the door to tear off when opening the door the next day.

1.8 Explosion!!!



It is very important never to leave The stove after start up or refueling, before the fire is established. (Typically 1 to 3 minutes)

Explosion can occur if filled with too much fuel in the stove, the production of large volumes of gas, which can explode if the air supply becomes too low.

It is an advantage for the next firing to leave a layer of ash lying in the bottom of the firebox.

Be careful when emptying the ashes out. There can be hot embers left for a long time.

Warning!



One must always use caution around the stove seen, as it gets very warm during use. (In excess of 90° C).

Children should avoid contact with the stove.

Setting up a fence if you have small children may be necessary.

Do not place flammable objects like drying racks, furniture, curtains too close to the stove.

1.9 Draft conditions and the chimney

Poor draft will not allow the stove to burn, as it should. The glass can soot, requires cleaning of the chimney more often, smoke can escape out when the door is open and it gives poor fuel efficiency. Leading to unnecessary polluting of the environment.

Good draft will allow the stove to achieve optimal combustion and the highest possible efficiency. Heta wood stoves are constructed so that it itself provides an optimal blend of combustion air. This provides a high efficiency/heat, clean glass and low environmental impact.

Minimum chimney draft for Inspire 40 insert is 11 pascal. It is the draft that the stove has been tested and approved on. The minimum draft is necessary to provide clean burning, beautiful flame picture, as well as achieving the rated efficiency.

There is a risk of smoke escaping into the room if the door is opened during vigorous firing, or if there is a lack of air supply to the room, for ex. if an extraction fan is in use.

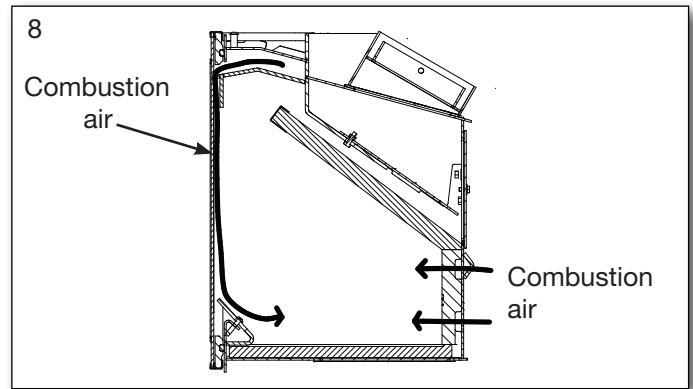

Flue gas temperature at the rated output is 215° C relative to 20° C.

Flue gas flow is: 3.4 g/sec.

Corresponding to 12.3 m³ / hr of combustion air by burning 1.0 kg of wood.

The chimney height and diameter, as well as the temperature difference between the flue gas and outside temperature generates the chimney draft. Chimney insulation is therefore important as new efficient stoves create lower flue temperatures. Wind and weather conditions also influence draft, in some cases it may be disadvantageous wind direction, combined with the position of the chimney can cause negative draft (it blows through the chimney), causing smoke escape from the stove.

Before using after a long period of inactivity, check that the chimney is free for any blockages. (soot build-up, bird nests, leaves etc.).

Reduced draft can occur when:

- The temperature difference is too small between smoke gasses and outdoor
- Too short of a chimney
- The outside temperature is high, and indoor temperature is low f. ex. in summer
- False air in the chimney
- Chimney is blocked
- Air tight house (lack of combustion air supply)
- Poorly placed chimney for the surroundings, for ex. the ridge and trees may cause turbulence

Good draft occurs when:

- The difference in temperature in the chimney (warmer) and outside temperature (colder)
- It is clear weather
- The chimney has the right height min 4 meters above the stove, and clear of the roof ridge

1.10 Fuel

Your new stove is EN approved for firing with wood fuel. You must therefore only burn clean, dry wood in your stove. Never use your stove to burn driftwood, as this may contain a lot of salt which can damage both the stove and the chimney. Similarly, you must not fire your stove with refuse, painted wood, pressure-impregnated wood or chipboard, as these materials can emit poisonous fumes and smoke.

Correct firing using well seasoned wood provides optimal heat output and maximum efficiency. At the same time, correct firing prevents environmental damage in the form of smoke emissions and reduces the risk of chimney fires. If the wood is damp and inadequately seasoned, a large proportion of the energy in the fuel will be used to vaporize the water, and this will all disappear up the chimney. Thus, it is important to use dry, well seasoned wood, i.e. wood with a moisture content of less than 20 %. Achieve this by storing the wood for 1–2 years before use.

Pieces of firewood with a diameter of more than 10 cm should be split before storing. The pieces of firewood should be of an appropriate length (approx. 19-25 cm) so that they can lie flat on the bed of embers.

If you store your wood outdoors, it is best to cover it.

Examples of fuel values

for different woods and their typical densities per cubic meter, specified for 100% wood with a moisture content of 18%.

Wood	kg/m ³	Wood	kg/m ³
Beech	710	Willow	560
Oak	700	Alder	540
Ash	700	Scotch pine	520
Elm	690	Larch	520
Maple	660	Lime	510
Birch	620	Spruce	450
Mountain pine	600	Poplar	450

It is advised not to use oil-containing woods like teak tree and mahogany, as this can cause damage to the glass.

Heating value in wood

You have to use about 2.4 kg normal wood to replace one litre of heating oil. All woods have

almost the same heating value per kg, which is about 5.27 kW/hour for absolute dry wood.

Wood with a moistness of 18% has a efficiency of about 4.18 kW / hour per kg, and one litre heating oil contains about 10 kW / hour.

CO₂ release

At combustion 1000 litres of heating oil forms 3.171 tons CO₂. As wood is a CO₂ neutral heat/energy source, you save the environment about 1.3 kg CO₂ every time you have used 1 kg normal wood.

1.11 Operational problems

The chimney must be swept at least once a year, we recommend the use of a NACS (national association of chimney sweeps) registered chimney sweep.

In the event of smoke or malodorous fumes are being produced, you must first check to see whether the chimney is blocked.

The chimney must, of course, always provide the minimum draft necessary to ensure that it is possible to regulate the fire. Please note, however, that chimney draft is dependent on the weather conditions. In high winds, the draft can become so powerful that it may be necessary to fit a damper in the flue gas pipe to regulate the draft.

When cleaning the chimney, soot and other deposits may come to fall on the baffle plate, remove and clean it. In cases where the wood burns too quickly, this may be due to excessive chimney draft. You should also check to make sure that the door seal and ash pan seal is intact and correctly fitting.

If the stove is generating too little heat, this may be because you are firing with wet wood. In this case, much of the heating energy is used to dry the wood, resulting in poor efficiency, potentially damaging the vermiculite and an increased risk of soot deposits in the chimney.

1.12 Chimney fire

In case of a chimney fire, which often results from incorrect operation/maintenance or prolonged use of damp wood, close the door and the air supply completely, to help slow/smother the fire. Call the fire department.

1.13 Troubleshooting table

Fault	Cause	Troubleshooting	Solution
Lighting problems. When the stove is cold, smoke seeps into the room. Once the combustion chamber has heated up, the stove burns well.	Inadequate chimney draft. The chimney only has sufficient draft when it is hot.	You can test using a lighter whether flame is drawn into the combustion chamber.	Improve the chimney.
The stove burns poorly after the warm-up phase, and the glass slowly soots up.	Soot in the flue pipe.	Check the flue pipe regularly, as the problem arises slowly.	Clean regularly, and limit the use of horizontal flue pipes. Do not use firewood which generates large quantities of ash.
If the stove burns poorly after start-up, and the glass slowly soots up.	Inadequate chimney draft.	The fault usually already occurs during lighting. Measure the chimney draft.	Improve the chimney draft.
	Insufficient air supply.	Check the air supply.	Read the operating instructions and instruct all users.
	Damp wood.	Use clean, dry wood with a maximum moisture content of 20%.	Firewood should ideally be dried for at least one year after splitting.
	Firewood pieces too large.	Optimal size – see the section for firewood, max. diameter 10 cm.	Use smaller pieces of firewood.
	Insufficient air supply to the room. Range hoods, airtight windows, etc.	Ensure there is sufficient fresh air supply, open a window, check the outdoor air supply.	Depending on the cause, windows must be opened or the outdoor air connection cleaned.
	Insufficient air supply to the room. Range hoods, airtight windows, etc	Ensure there is sufficient fresh air supply, open a window, check the outdoor air supply.	Depending on the cause, windows must be opened or the outdoor air connection cleaned.
The vermiculite in the combustion chamber is becoming very worn.	Wood and flue gases wear down the vermiculite.	Investigate whether the wear is normal.	Normal wear and minor cracks are of no significance. It should be replaced when the steel of the combustion chamber is visible.
Too rapid combustion.	Too much chimney draft.	To test, you can open the cleaning hatch, but remember to close it again.	Measure the chimney draft and install a damper in the flue pipe if necessary.
	The door or ash pan/drawer seal is defective.	While cold, close a piece of paper in the door – the seal should hold the paper gently in place so it does not fall out by itself. Normal wear.	Replace the seal.
The vermiculite in the combustion chamber is cracked.	Shocks or impacts while adding firewood.	Normal wear	Cracks only have cosmetic significance. Replace when the steel of the combustion chamber is visible.
Steel surfaces in the combustion chamber have oxidised.	The temperature in the combustion chamber is too high.	Unsuitable fuel is being used (such as coal). Check the quantity of firewood being used, read the operating instructions.	If there are clear cracks or weaknesses in the stove body, it must be replaced.
The stove whistles	Too much chimney draft	To test, you can open the cleaning hatch, but remember to close it again.	Install a damper.
The stove 'clunks'	Usually due to tension in the metal plates.	Generally only occurs while heating up and cooling down.	Adjust the metal plates.
The stove ticks	Normal expansion and contraction due to temperature changes.	A normal sound.	Ensure that the temperature in the combustion chamber is as constant as possible.
The stove creaks.	The temperature in the combustion chamber is too high.	Use less firewood. Also check the seal in the ash pan/drawer.	See the operating instructions.
The stove smells. The surface is steaming.	The paint on the stove surface is not yet fully hardened.	See the operating instructions regarding the first firing.	Ensure there is sufficient ventilation.
Condensation in the combustion chamber.	Moisture in the vermiculite.	Check the condition of the vermiculite.	Evaporates by itself after the stove has been lit a few times.
	Damp wood.	Measure the moisture content.	Use dry firewood.
Condensation from the flue pipe.	The pipe is too long or the chimney is too cold.	Check the flue pipe's length and heat loss.	Improve the flue pipe, insulate the chimney.
	Damp wood	Measure the moisture content.	Use dry firewood.

1.14 Maintenance

The surface of the stove is treated with a heat-resistant paint. The stove should be cleaned with a damp cloth.

Any damage to the surface in the form of chips or scratches can be repaired using touch-up paint, which is available in spray cans.

1.15 Cleaning the glass

Incorrect firing, for example using wet wood, can result in the viewing window becoming covered in soot.

This can be removed easily and effectively using glass cleaner applied using a cloth.



Never apply spray directly to the glass.

1.16 Diagram for the maintenance

Maintenance / Period	Stove Owner					Qualified Technicia	
	Before Autum	Daily	2-3 days	30 days	60-90 days	1st Year	2st Year
Cleaning the chimney (see. Chimney)	C						
Cleaning the chimney and stove	C				C		
Cleaning the stoves firebox	C	VI			C		
Cleaning combustion air intake	C				C		
Cleaning ash bucket (small)	C		VI				
Cleaning ash bucket 8 Liter	C		VI	C			
Cleaning of the firebox	C	VI		C			
Checking / switch, gasket for door	C/S	VI					C/S
Checking / changing, gasket for glass	C/S	VI					C/S
Checking / switch, gasket for ashpan	C/S	VI					C/S
Checking / changing gasket for flue pipe	C/S	VI					C/S
Checking / changing vermiculite	C/S	VI					C/S
Lubricate hinges	L	VI			L		
Lubricate lock	L	VI			L		

For the lubricant used a heat-resistant product. (300c)

C = Cleaning

C/S = Checking /Switch

L = Lubricate

VI = Visual Inspection, pos. cleaning/replacing/adjusting

1.17 Cleaning after sweeping or before replacing vermiculite stones

Note: it may be necessary to clean/vacuum the holes and air ducts behind the rear stone

Removal sequence of stones.

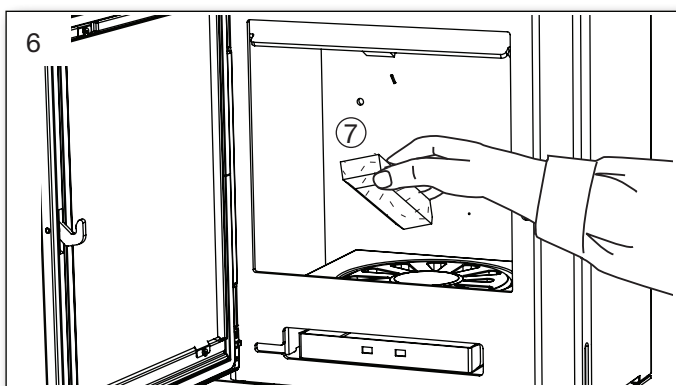
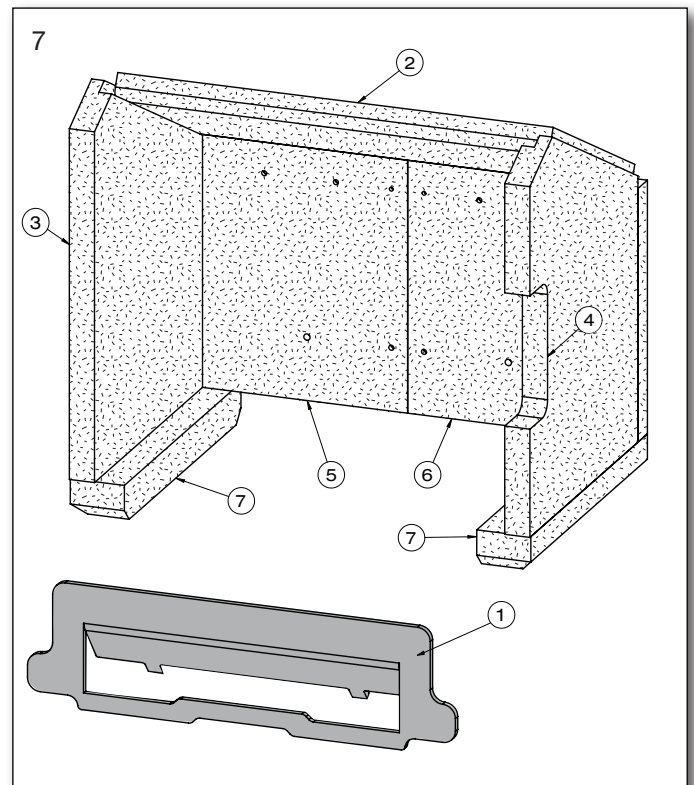
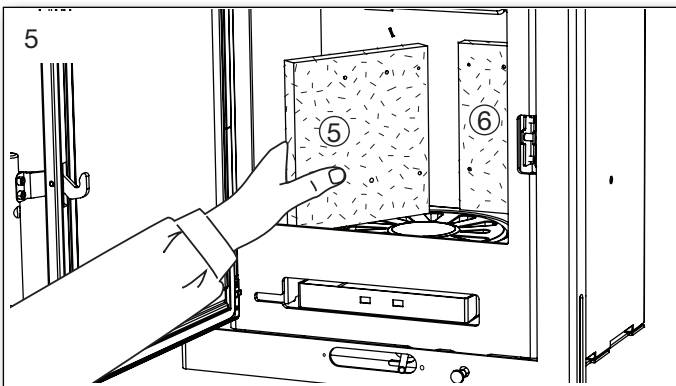
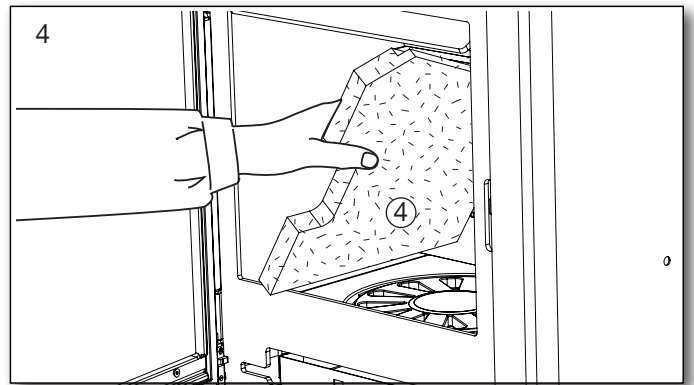
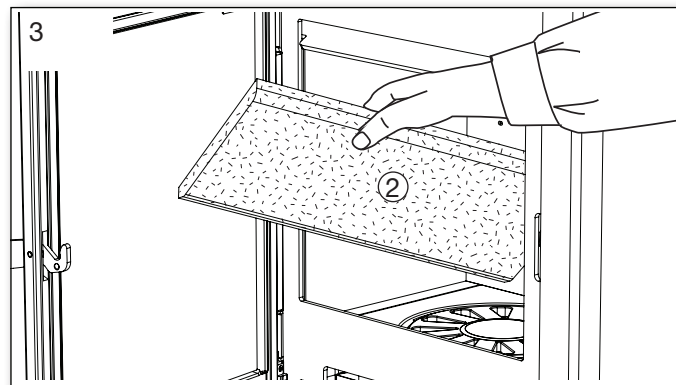
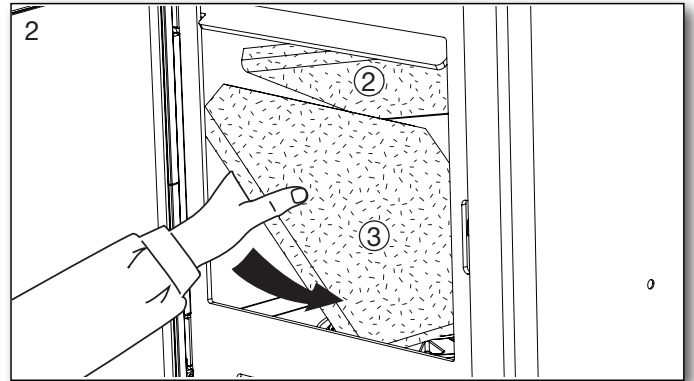
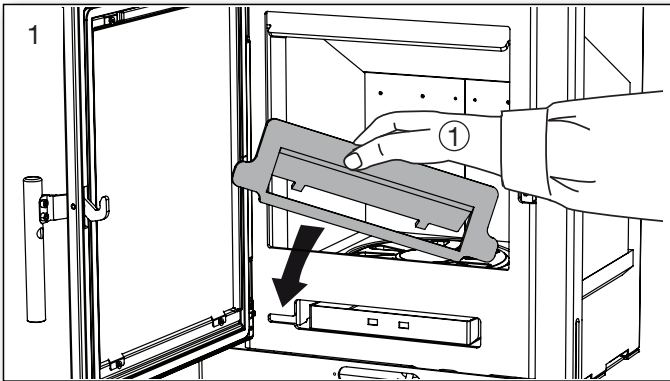

Replace in reverse order. Starting with Fig. 6.

1.18 Parts Inspire 40

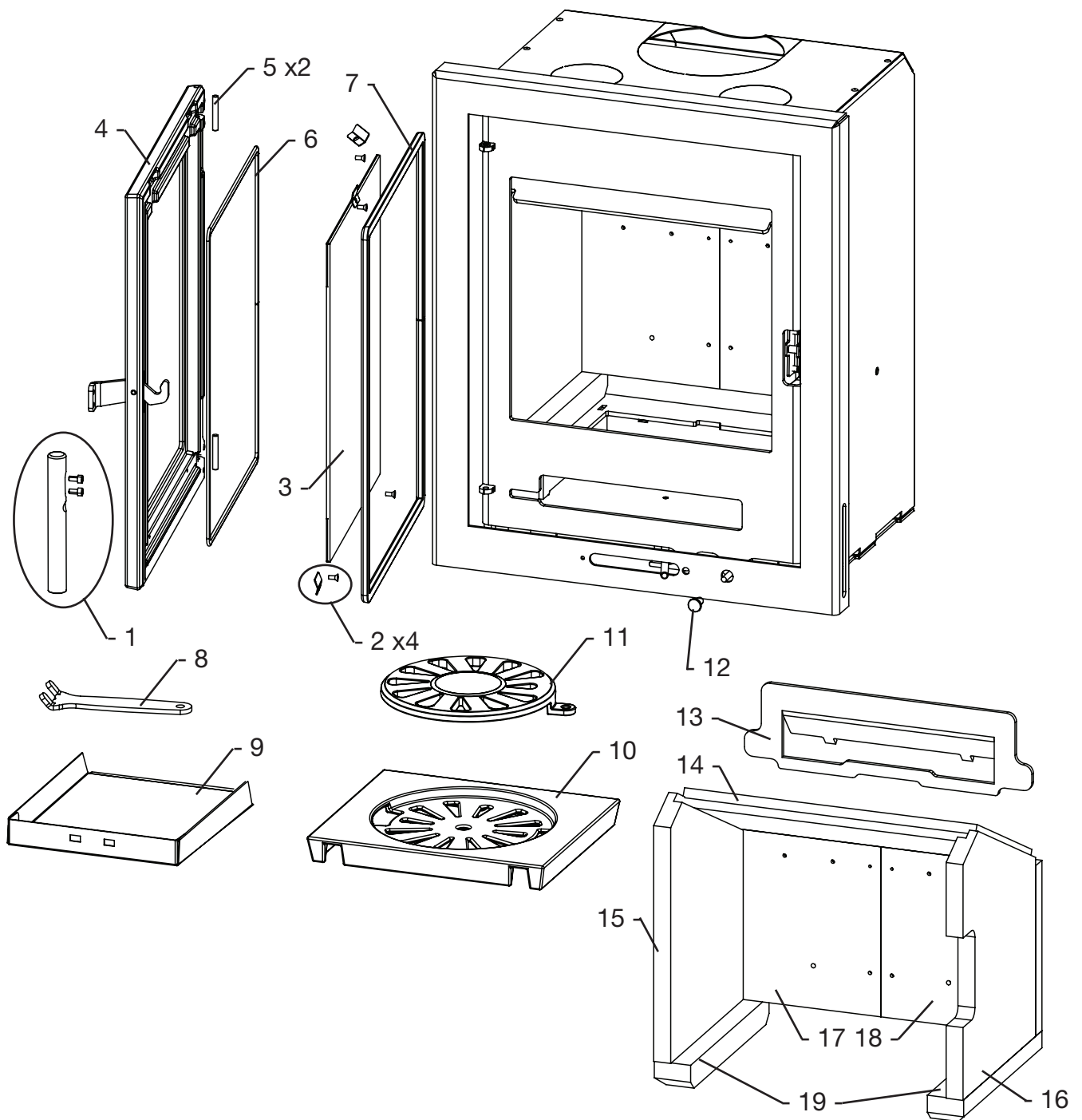

Pos. No.	Name	Qty.	Pos. No.	Name	Qty.
1	5013-0008 Handle	1	11	0030-0201 Shaking grate, Ø195 mm	1
2	1013-0529 Glass clips	4	12	0015-2013 Shaking grate handle	1
2	0008-2306 M4x8 A2	4	13	1019-0028 Log retainer	1
3	0021-0053 Glass	1	14	0023-0197 Baffle plate	1
4	4005-0042 Door, with glass tape	1	15	0023-0153 Left stone	1
5	0008-9013 Hinge Pin	2	16	0023-0152 Right stone	1
6	0023-3013 Glass seal 3x8 mm	1.3 m	17	0023-0194 Left back stone	1
7	0023-3008 Door seal ø12	1.5 m	18	0023-0195 Right back stone	1
8	1020-0001 Handle for ash pan	1	19	0023-0196 Bottom stone	2
9	1018-0216 Ash pan	1			
10	0030-0020 Cast bottom	1			

1.19 Stove data table in accordance with en 13229 testing

With insulated chimney

Stove type	Distance to flammable materials			Distance to furnitures from the stove mm
	at the sides mm	to floor mm	rear the stove mm	
Inspire 40				
Classic floor model	150	180	110	900
Flat floor model	150	180	110	900
Flat wall model	150	180	110	900
Hidden wall model	150	180	110	900

1.20 Stove data table in accordance with en 13229 testing

Tested as a freestanding oven and with uninsulated flue

Stove type	Nominal flue-gas temperature, at 20°C room temperature C°	Flue mm	Fuel volume kg	Draft min. mbar	Nominal output tested kW	Actual efficiency %	Distance to flammable materials			Distance to furnitures from the stove mm	Stove weight kg
							at the sides mm	to floor mm	rear the stove mm		
Inspire 40											
Classic floor model	215	ø125	1	0,11	4	84	400	180	210	900	82
Flat floor model	215	ø125	1	0,11	4	84	400	180	210	900	82
Flat wall model	215	ø125	1	0,11	4	84	400	180	210	900	81
Hidden wall model	215	ø125	1	0,11	4	84	400	180	210	900	83

Flue temperature 259° The nominal output is the output to which the stove has been tested.

The test was carried out with the combustion air 80%.

1.21 Guarantee

Heta wood stoves, are subjected to a strict quality control during production and before delivery to the dealer. Therefore, the duration of the warranty is **5 years** on this product, covering manufacturer's defects, **1 year** on paint adhesion defects from purchase date from Heta and a 3 months total warranty for seals, vermiculite and glass from the date of sale from the dealer.

Claims concerning stoves older than **3 months**, will be assessed by our quality team on a one-by-one basis. Report all claims to your dealer or local Heta representative, who in turn will contact Heta to solve the claim. To file a claim please provide date of installation, picture of the silver data sticker, model and a description of the issue and pictures.

The guarantee does not cover:

- Wearing parts / fragile parts such as:
- Vermiculite elements in the combustion chamber. • Glass • Seals
- The cast bottom or shaking grate
- Surface or paint deteriorations due to excessive humidity, salinity or other aggressive environment
- Damage caused by improper use
- Transportation costs for warranty repair
- Assembly / disassembly of warranty repair
- Any secondary damages of the stove or it's environments due to negligence of any initial damages whether this damage is covered or not by the manufacturers guarantee.

Warning



Inadequate installation, unauthorized alteration to the stove or the use of non-original parts will void the guarantee.

Installation Instructions

Contents

2.	Installation instructions	15
2.1	Distance requirements	15
2.2	Floor	15
2.3	Chimney connection	15
2.4	Combustion air	16
2.5	Clearances for installation.....	16-17
2.6	Installation of the stove	18
2.7	Change to 45° flue outlet.....	18
2.8	Stovedrawings/measurments	19
2.9	Fitting the convection case	20
2.10	Fitting the flue collar on the chimney	21
2.11	Fitting the stove.....	21
2.12	Fitting the flue collar to the stove.....	21
2.13	Mounting the frame.....	21-23
3.	Connecting external air supply from behind	24
4.	Connecting external air supply from below	25
5.	Appendix A	26

Remember

The stove and chimney installation, must comply with local regulations, including those referring to national and European standards.

2. Installation instructions

The stove installation must be in accordance with national, European and possibly local regulations. You must follow local regulations with regard to installation of chimney and connection to the chimney. We recommend that you let a professional Heta dealer install the stove. Alternatively, you can ask the local chimney sweep before installation. Be aware that it is always the owner himself who has responsibility for ensuring that applicable rules are complied with.

A modern stove places heavy demands on the chimney due to the high efficiency. It may be necessary to enhance or even replace an old chimney.

Remember

1. Always ensure free access to any cleaning doors in a chimney.
2. Always ensure ample fresh air to the room.
3. Exhaust/extraction fans in the house can reduce or create negative draft in the chimney. Reduced draft can lead to the stove having adverse combustion properties. It may result in smoke coming out of the stove when the door is open. A negative draft due to an exhaust/extraction fan can cause the chimney to work in reverse, drawing smoke into the house because of the fan.
4. Any air vents must not be covered.

2.1 Distance Provisions

There is a difference between installation next to flammable wall or non-flammable wall. If the wall is made of non-flammable material, the stove in principle may be placed flush against it.

Inserts are generally only intended for installing in existing open fireplaces or in a wall built of non-combustible material. There must be adequate space between the wall and the convection case. This is to avoid damage to the masonry/wall when the stove expands when in use.

Minimum distances to combustible material found on the table on page 13, the data plate, as well as drawings. Pay special attention to the distance to flammable floor (180 mm), which is also applicable, although there is a steel/glass plate on the floor. If the floor is made of, for ex. concrete, tile or similar, there may not be combustible materials for at least a depth of 180

mm, valid from the bottom edge of the door on the insert.

Distances for installation see page 16-17.

2.2 Floor

You must ensure that the floor can support the weight of the stove and a top-mounted steel chimney.

In front of the fireplace insert, the substrate must consist of non-combustible material, for ex. Steel/glass plate, stone or tile floor. The size of the non-combustible surface must follow the applicable national and local regulations. Protecting your floor from embers that may fall out of the oven.

Distances see data table page 13, distance from flammable floor: 180 mm. When the stove is installed with a convection case, it can be installed on a 12 mm noncombustible hearth. Providing the floor is also noncombustible.

Pay special attention to the distance from flammable floor, which is also valid even if there are a steel, glass, stone or tile over flammable materials.

2.3 The chimney connection

The chimney opening must follow national and local regulations. However, the area of the opening should never be less than 115 cm², which corresponds to a diameter of 121 mm. If a damper is fitted in the flue gas pipe, there must always be at least 20 cm² of free passage, even when the damper is in its “closed” position.

If local regulations permit, two contained stoves can be connected to the same chimney. However, you must abide by local regulations regarding the distance between the two connections. The Inspire 40 insert can be installed with a horizontal straight back outlet. Maximum length of the pipe should be 500 mm with a 5” diameter. Minimum draft of 11 pascal is required.

The insert must never be connected to a chimney that is linked to a gas fire stove.

An efficient stove makes high demand on chimney properties – so always have your local chimney sweep evaluate your chimney.

Connection to a brick chimney

Brick a thimble into the chimney and seat the flue gas pipe in this.

The thimble and flue gas pipe must not penetrate the chimney opening itself, but must be flush with the inside of the chimney duct. Joints between brickwork, the thimble and flue gas pipe must be sealed with fireproof material and / or beading. Heta A/S stresses that it is of utmost importance that this is done correctly with very tight joints. As mentioned earlier, we recommend that setup and installation be left to a professional Heta dealer.

Connection to a steel chimney

When fitting a connection from a top outlet stove directly to a steel chimney, we recommend fitting the chimney tube inside the flue gas spigot so that any soot and condensation drops into the stove itself rather than collecting on the exterior surface of the stove.

For connections to chimneys that are run through ceilings, all national and local regulations regarding distance to flammable material must be followed. It is important that the chimney is fitted with roof support so that the top panel of the stove is not required to bear the entire weight of the chimney (excessive weight may damage the stove).

2.4

Combustion air and Ventilation

The insert is approved as a room air dependent insert in accordance with EN 13229. All the combustion air in the inset stove comes from the room in which it is fitted. However, by connecting a sealed air inlet to the insert stove's air intake connector, the stove can be supplied with external combustion air. In this respect, the following requirements must be met:

- Only approved materials may be used from the ventilation unit to the air inlet vent.
- The air inlet vent must be fitted correctly and insulated to prevent formation of condensate. The cross section of the vent and grille must be at least 78 cm².
- If the vent leads out into the open air, please note that the grille must be fitted with suitable wind protection. There must be no risk that the grille can get clogged by leaves, etc.

Ventilation

Adequate ventilation must be provided in accordance with building regulations (Doc J Oct 2010) especially when installing in newer build properties when the stove is not going to be installed to an outside air supply.

The Inspire 40 has a nominal output of less than 5kW and does not need additional ventilation in older properties where it will be ventilated by natural leakage.

Houses built after 2008 where the air leakage rate is less than 5 m³ / hour / m² then a ventilator equivalent to 550 mm² per kW output will be required (4.5 kW x 550 mm² = 2475 mm²) unless the stove is connected to an outside fresh air supply.

2.5 Clearances for installation EN 13 229

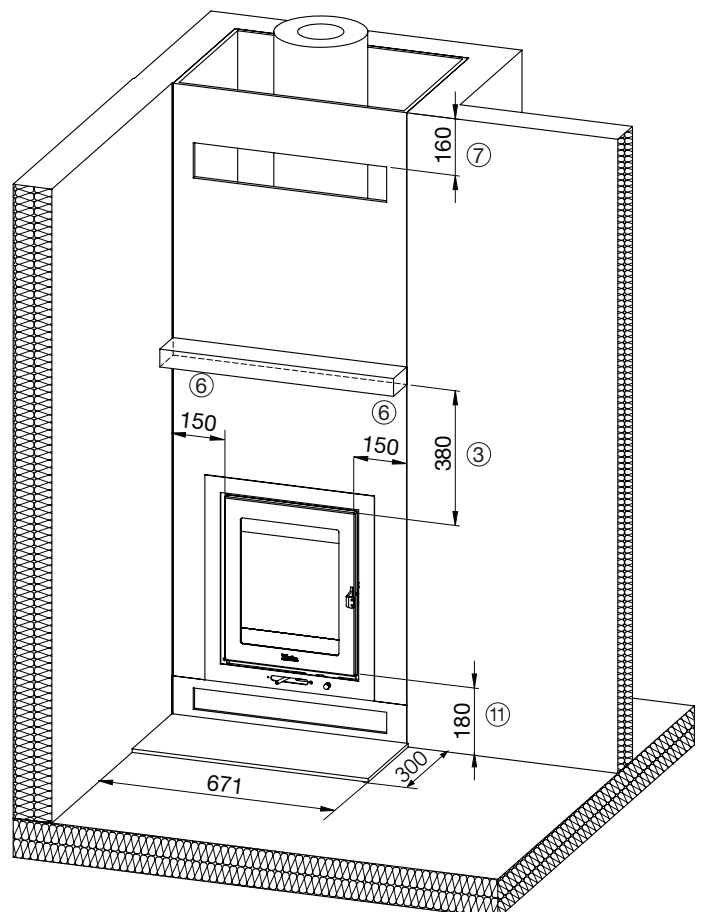

The Building materials that are used in safety test and shown in illustrations on this page, with No. 8. has a thermal conductivity of max. ($= <0.36 \text{ W (m} \cdot \text{K)}$)

1. Min. 110 mm convection rear
2. Min. 120 mm convection in the sides
3. Min. 380 mm from the convection cabinet to the lower edge of the shelf
4. Pipes must be insulated
5. Furniture safety distance min. 900 mm
6. Distance to side wall to the stove front 150 mm

7. Min. 160 mm from top edge of convection outlet to a combustible material
8. Not combustible 12,5 ($= <0,36 \text{ W/(m} \cdot \text{K)}$)
9. Floor board: Min. 150 mm to combustible flooring to the side of the stove door
10. Floor board: Min. 300 mm to combustible flooring in front of stove
11. Min. 180 mm from front of the insert to combustible floor
12. Shelf

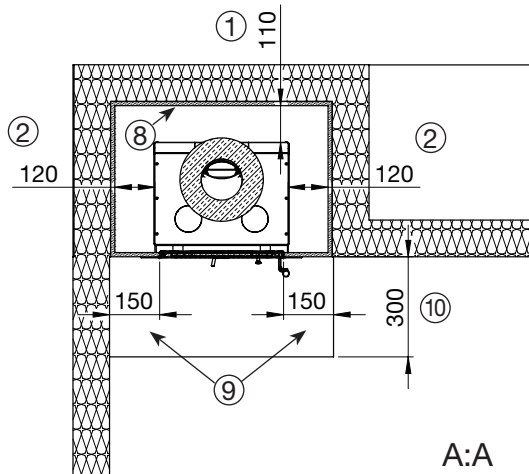
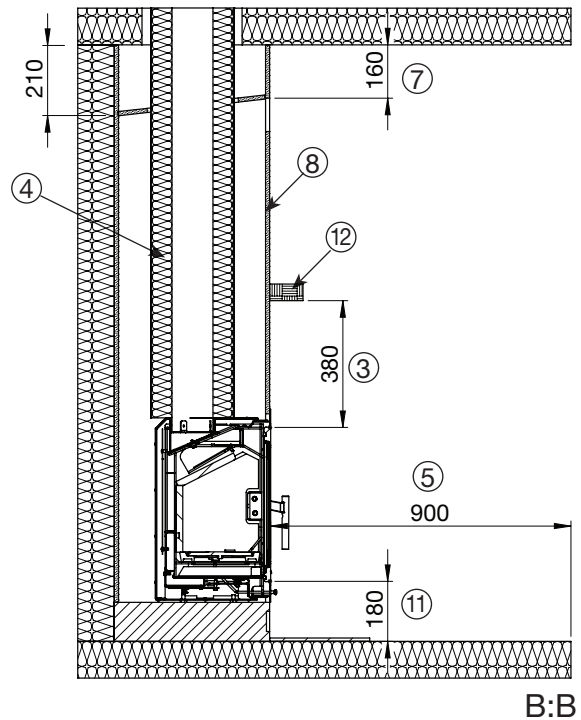
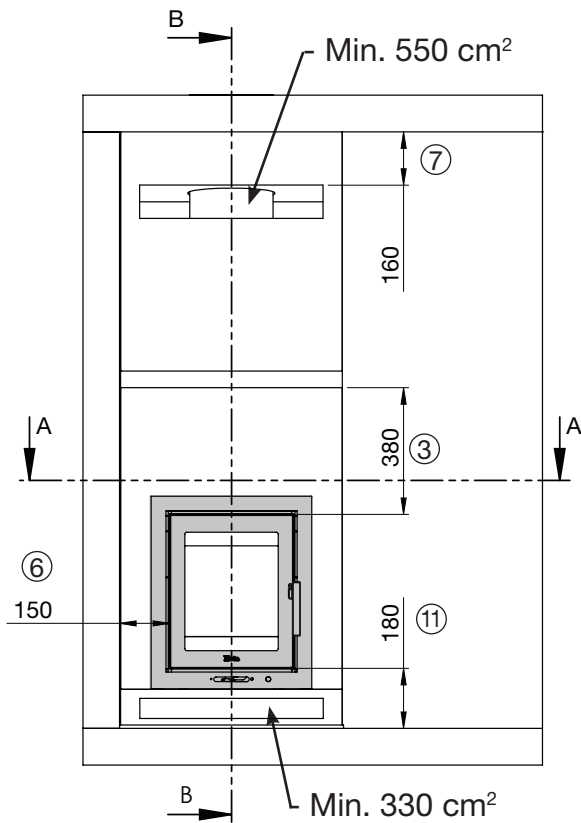

The dimensions are the minimum dimensions, unless otherwise stated.



Not combustible material

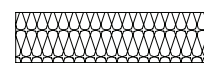

Combustible material



Other combustible material

2.6 Installation of the stove

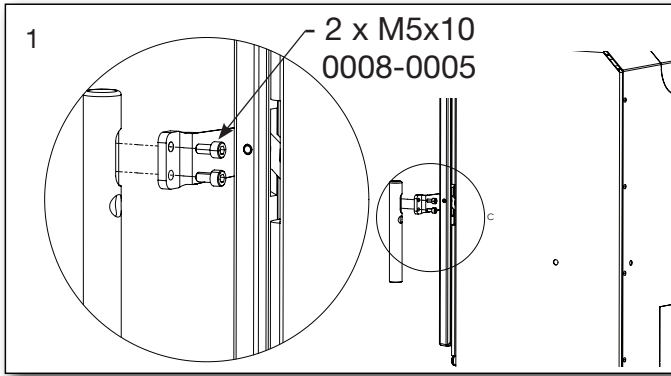

Attaching the door handle 0016-0031

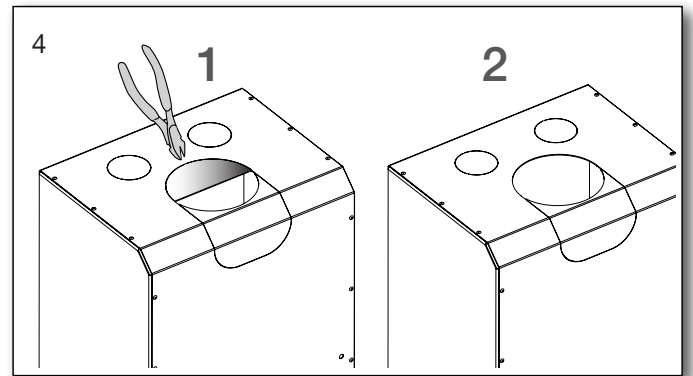
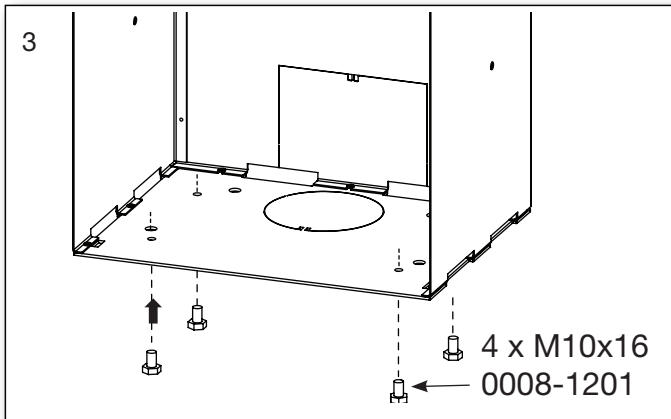
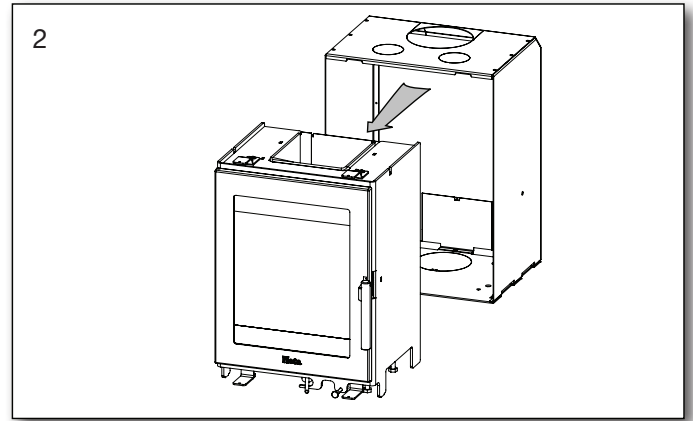

Flue outlet straight up.

2.7 Change to 45° flue outlet

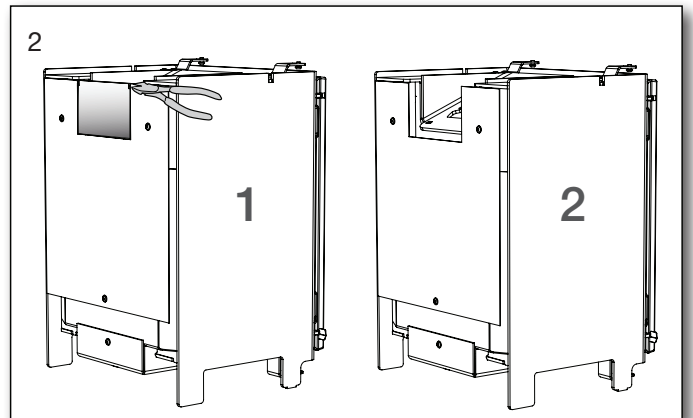
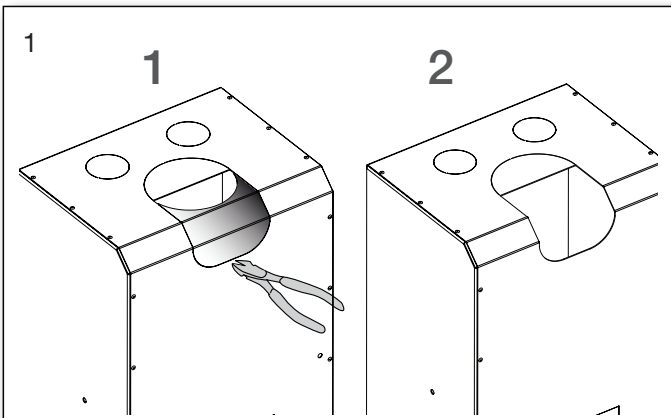

2.8 Stovedrawings/measurments

Classic floor model frame no. 2110-0005

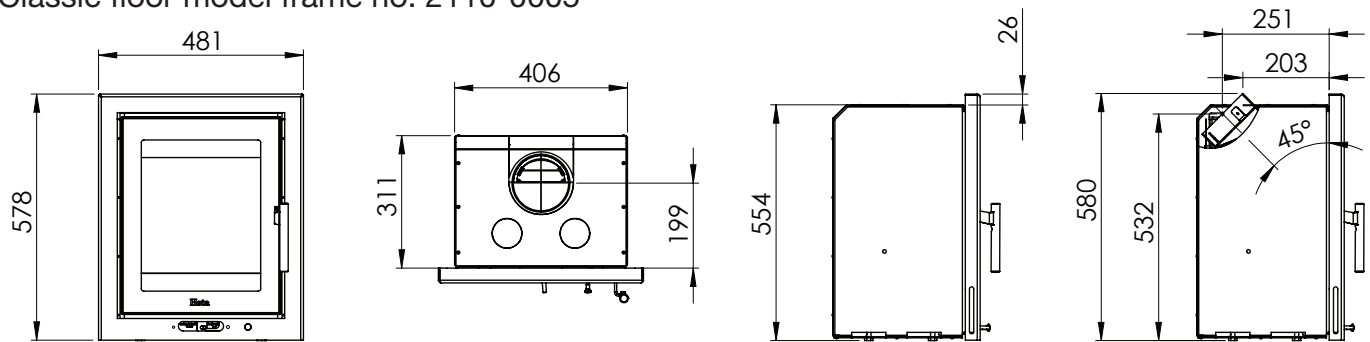

Flat floor model frame no. 2110-0006

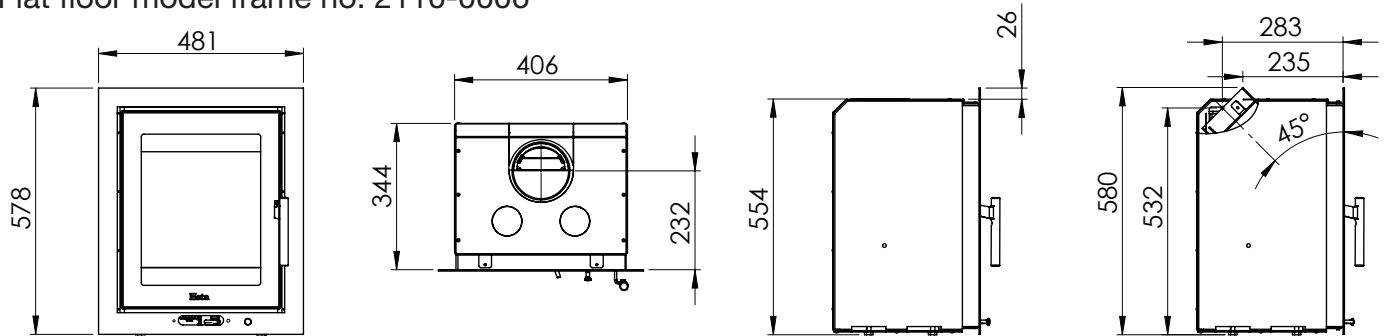

Flat wall model frame nr. 2110-0007

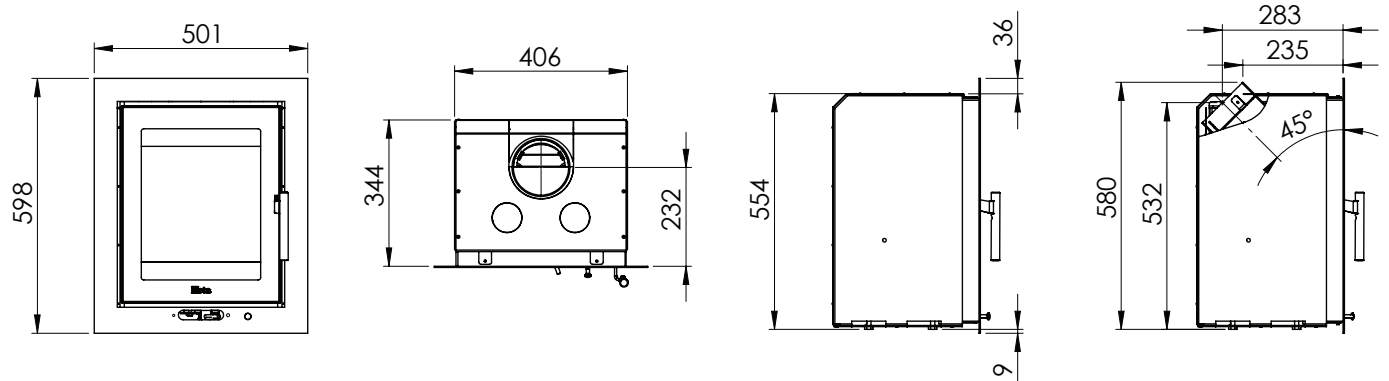

Hidden wall model frame nr. 2110-0008

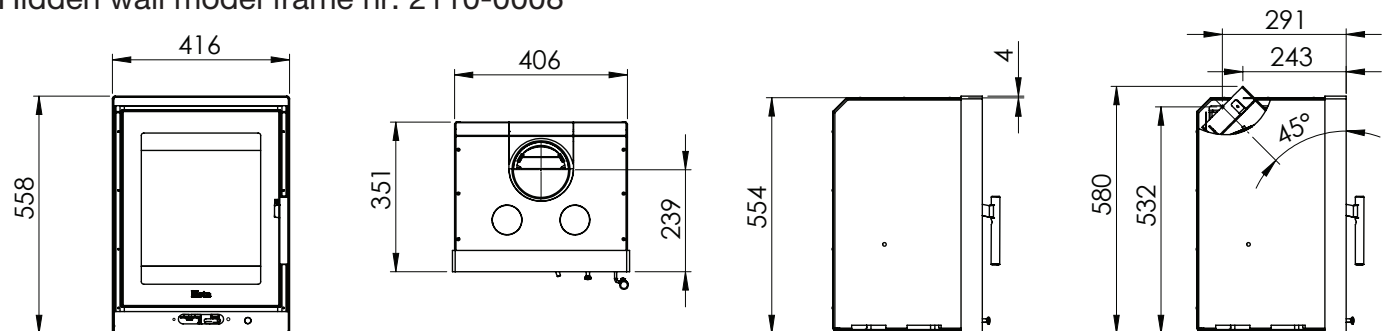

Murhuls mål minimum:

Inspire 40 Classic floor model, Flat floor- and wall model

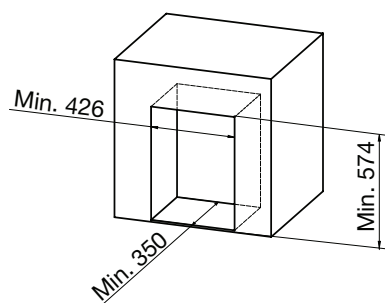

Inspire 40 Hidden wall model

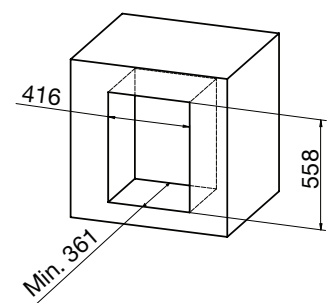

2.9 Fitting the convection case

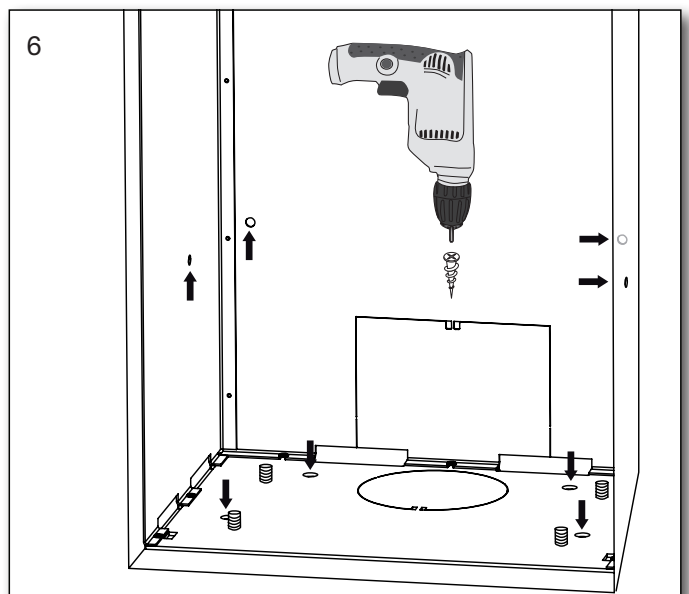
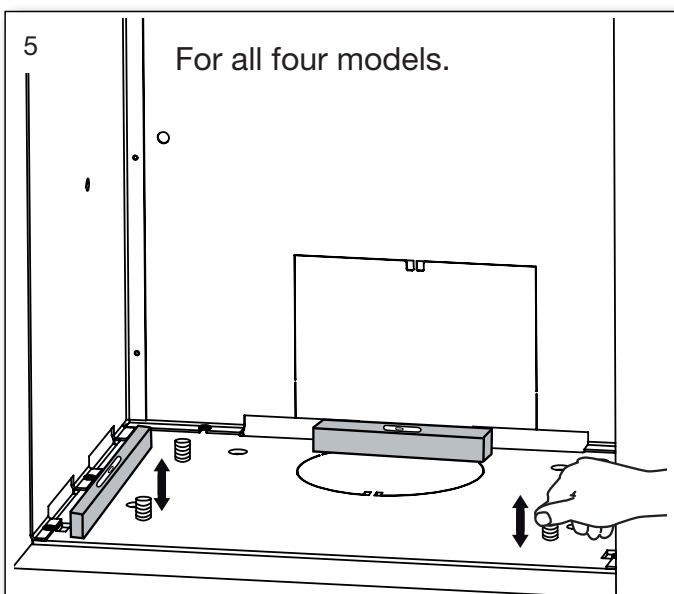
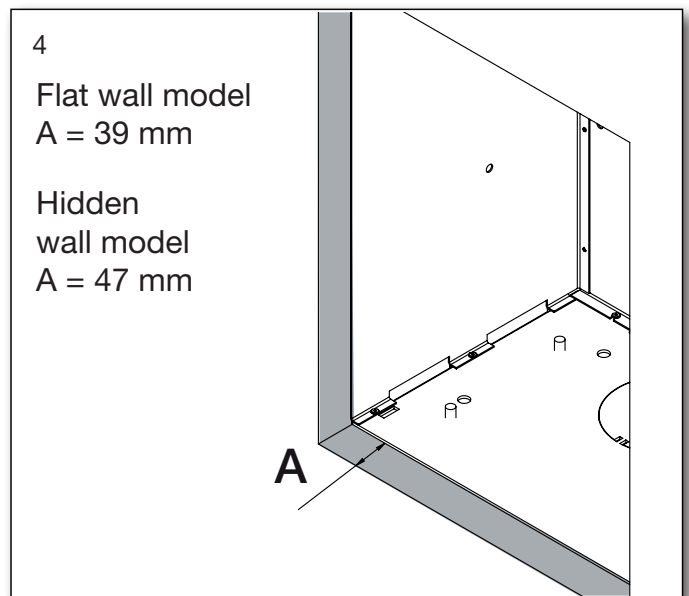
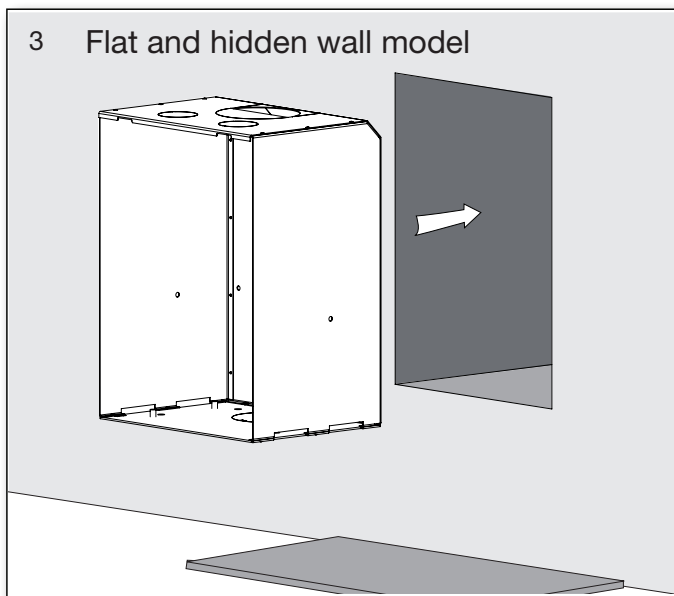
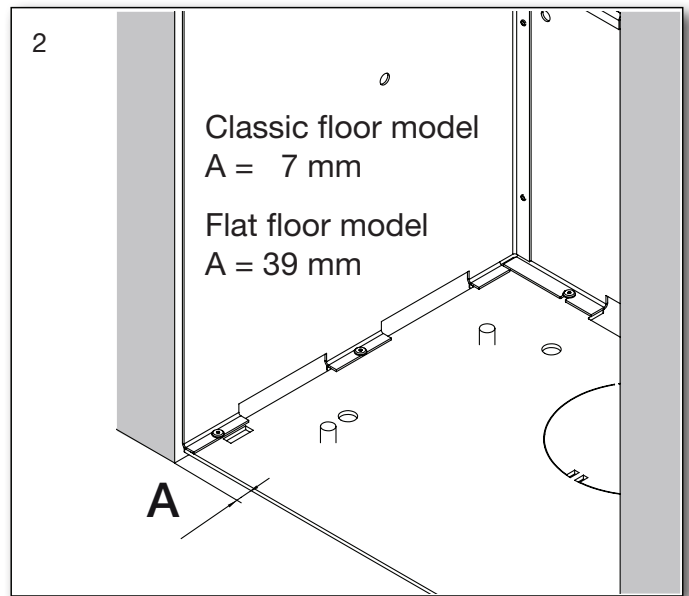
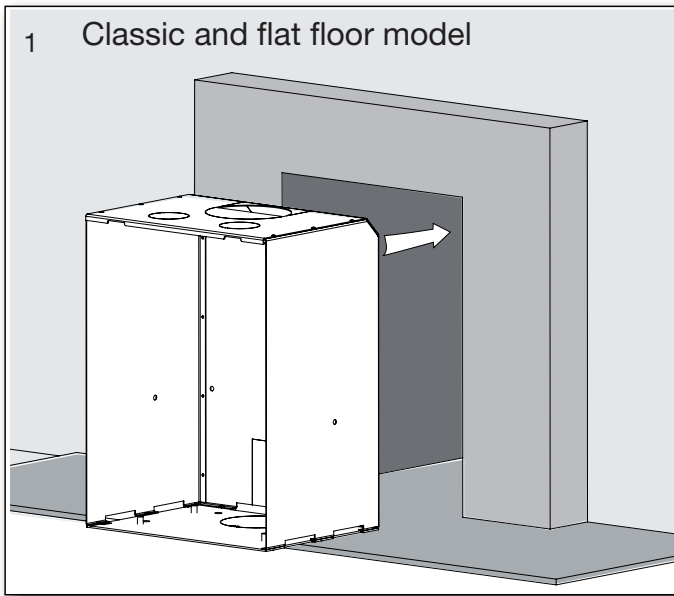

Adjust the convection cabinet so it is level.

The convection cabinet may be affixed to the wall as shown in fig. 6. Screws are not included.

2.10 Fitting the flue collar on the chimney

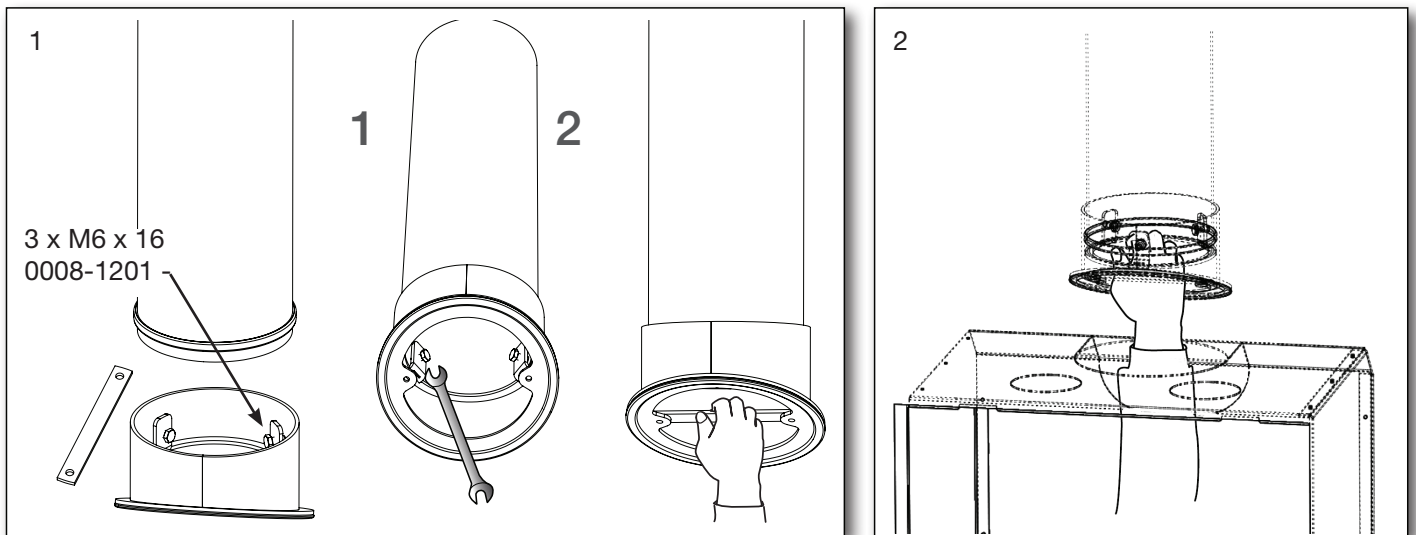

2.11 Fitting the stove

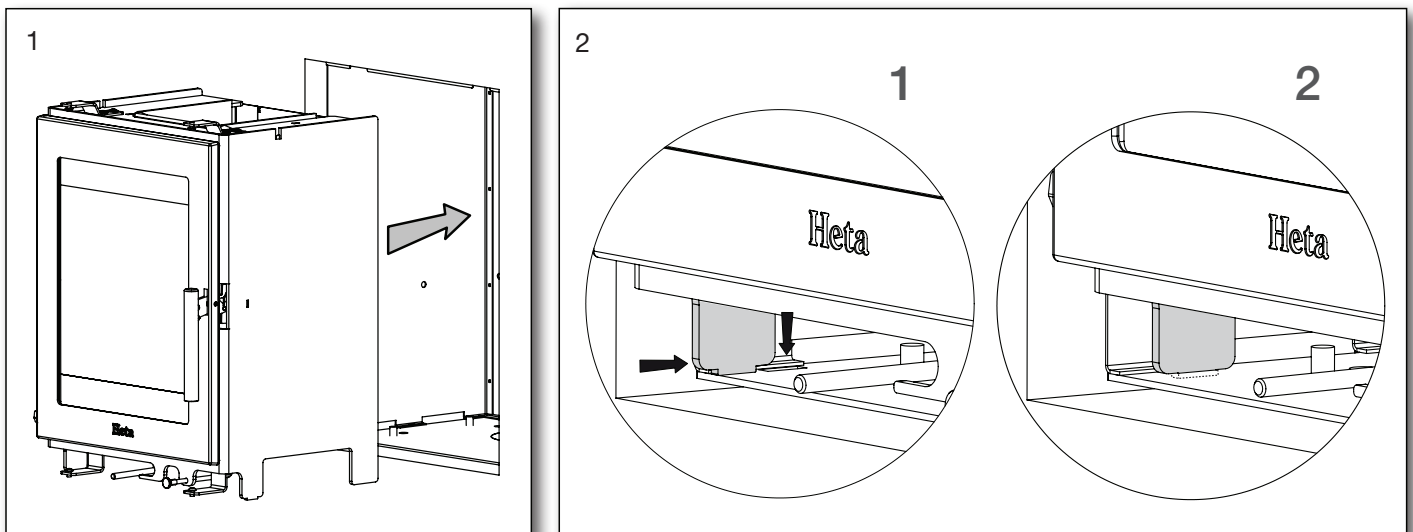

2.12 Fitting the flue collar to the stove

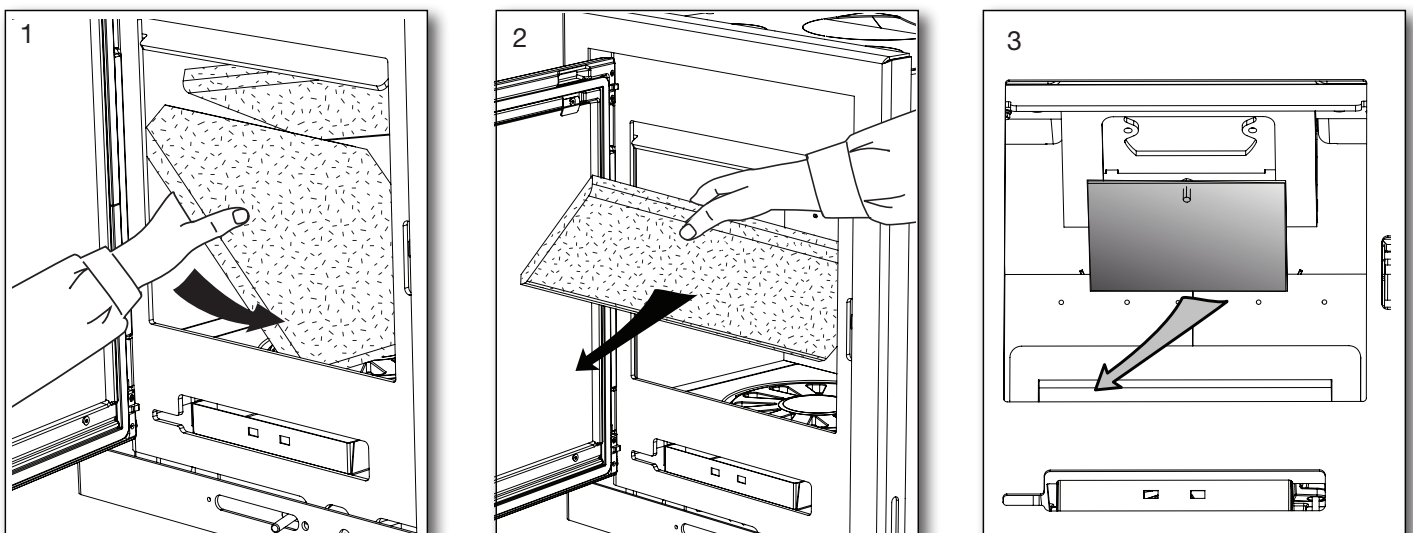

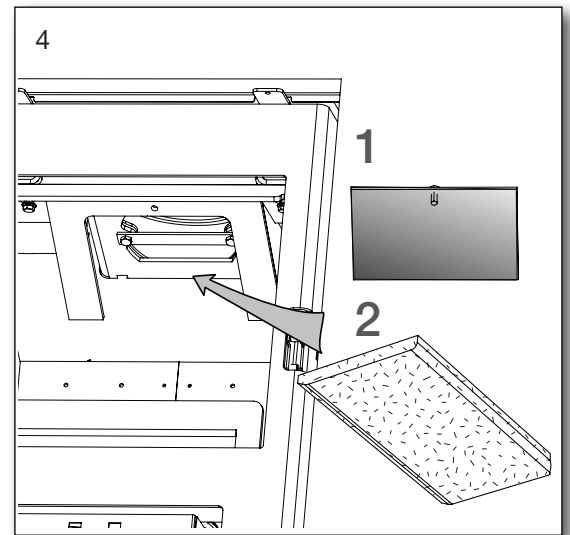
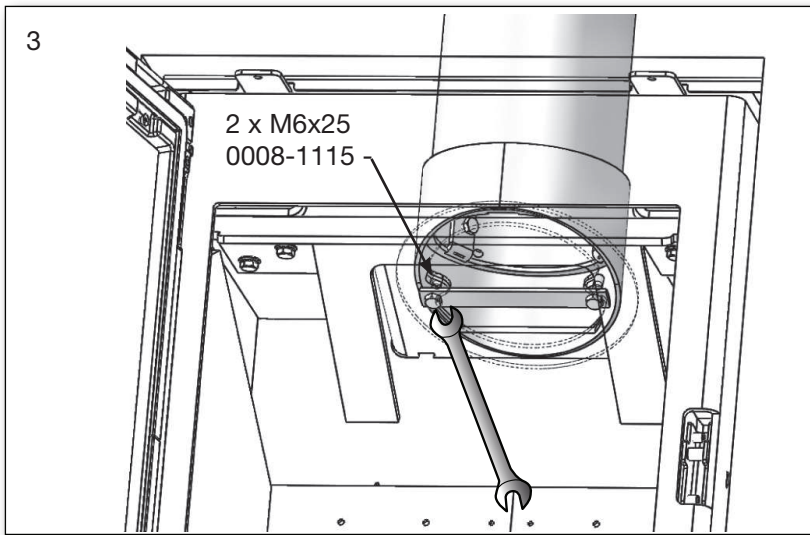

For flue outlet installation 45° backwards, turn the flue pipe connector 180°.

2.13 Mounting the frame

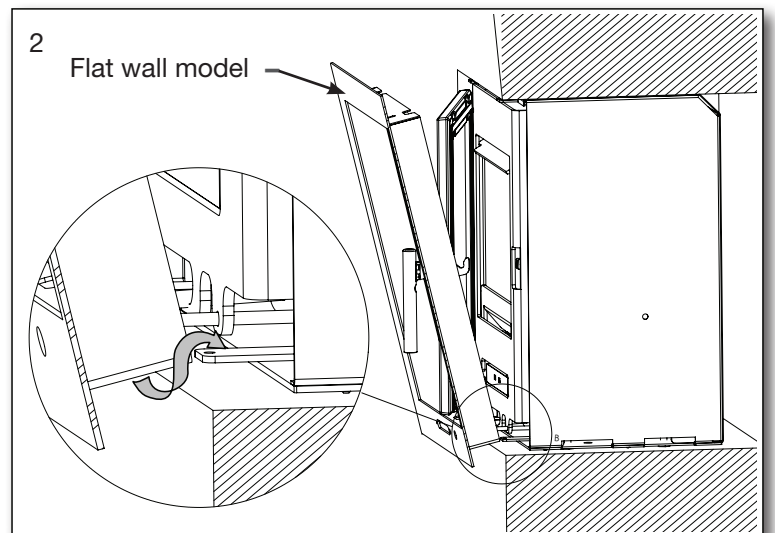
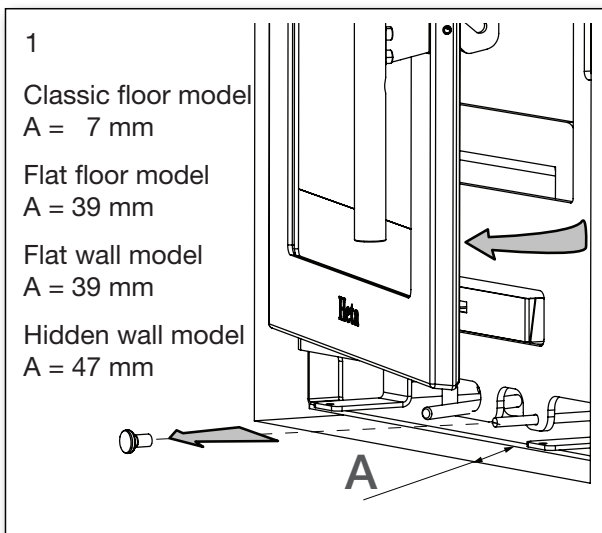

Flat wall model is given. Fitting for all four models.

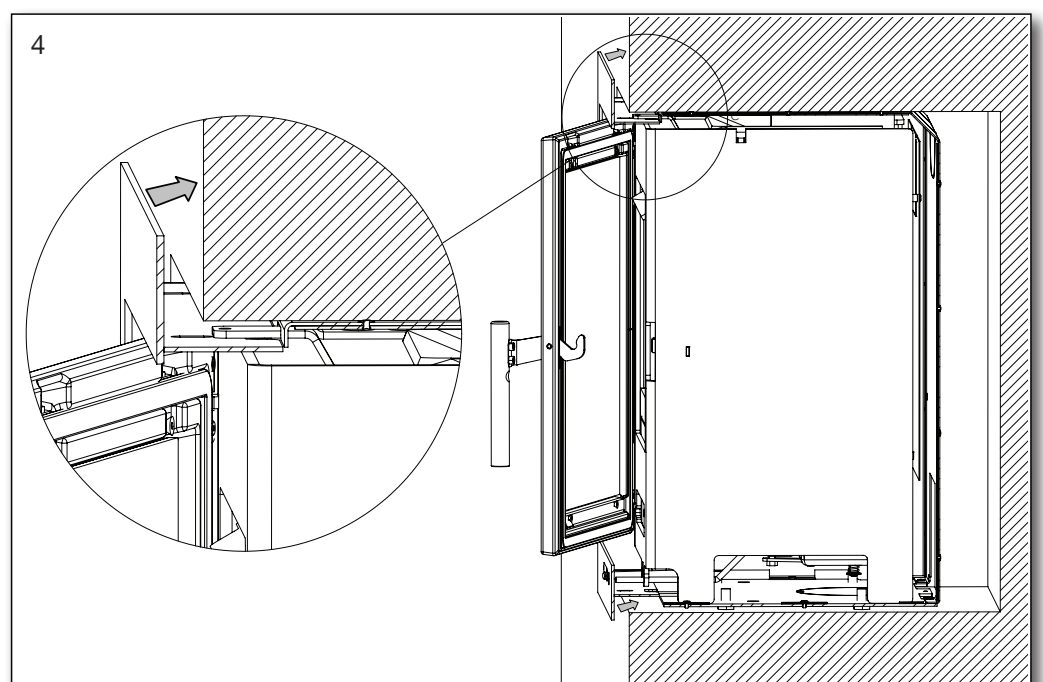
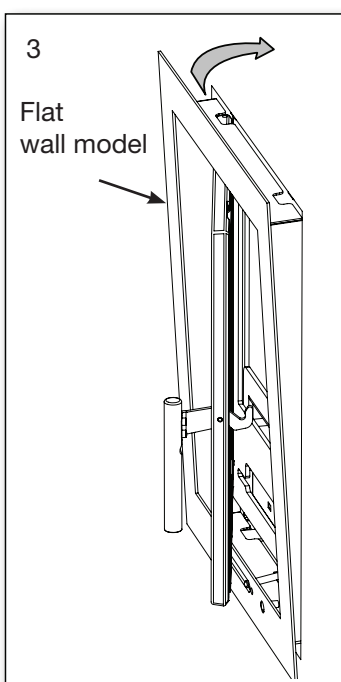

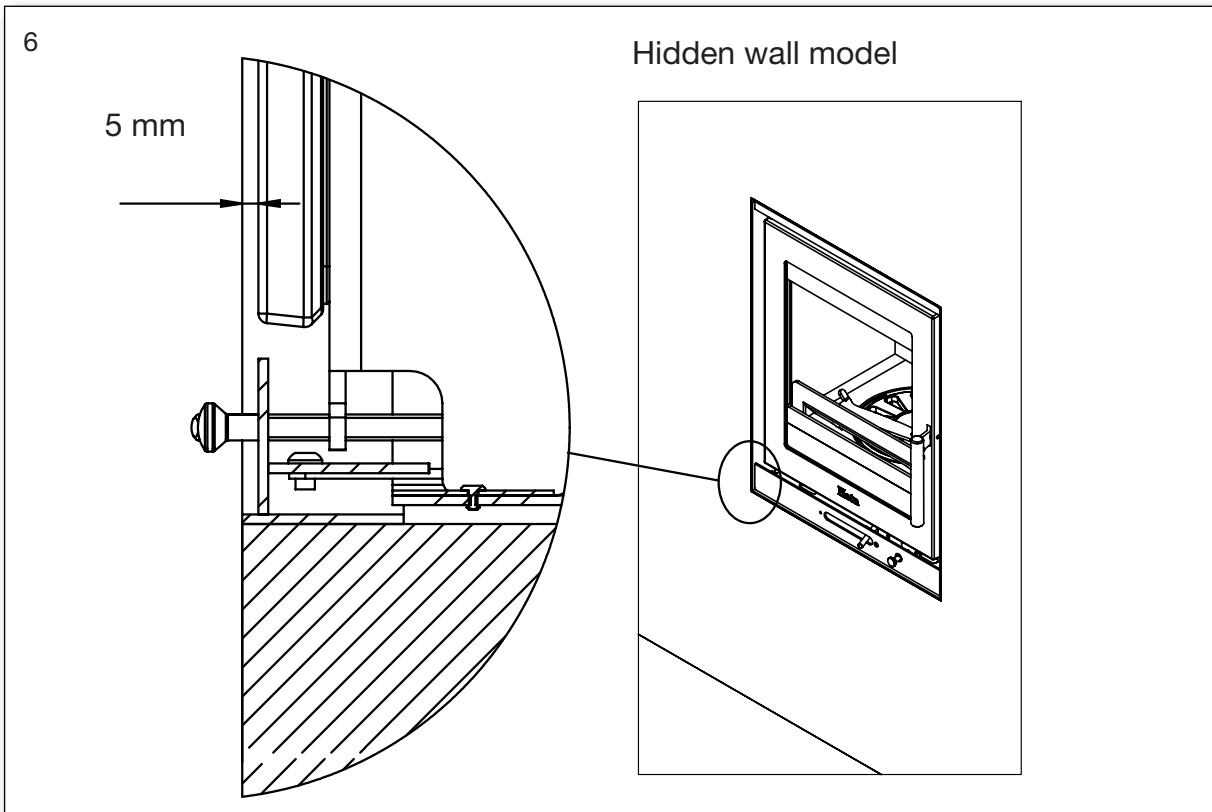
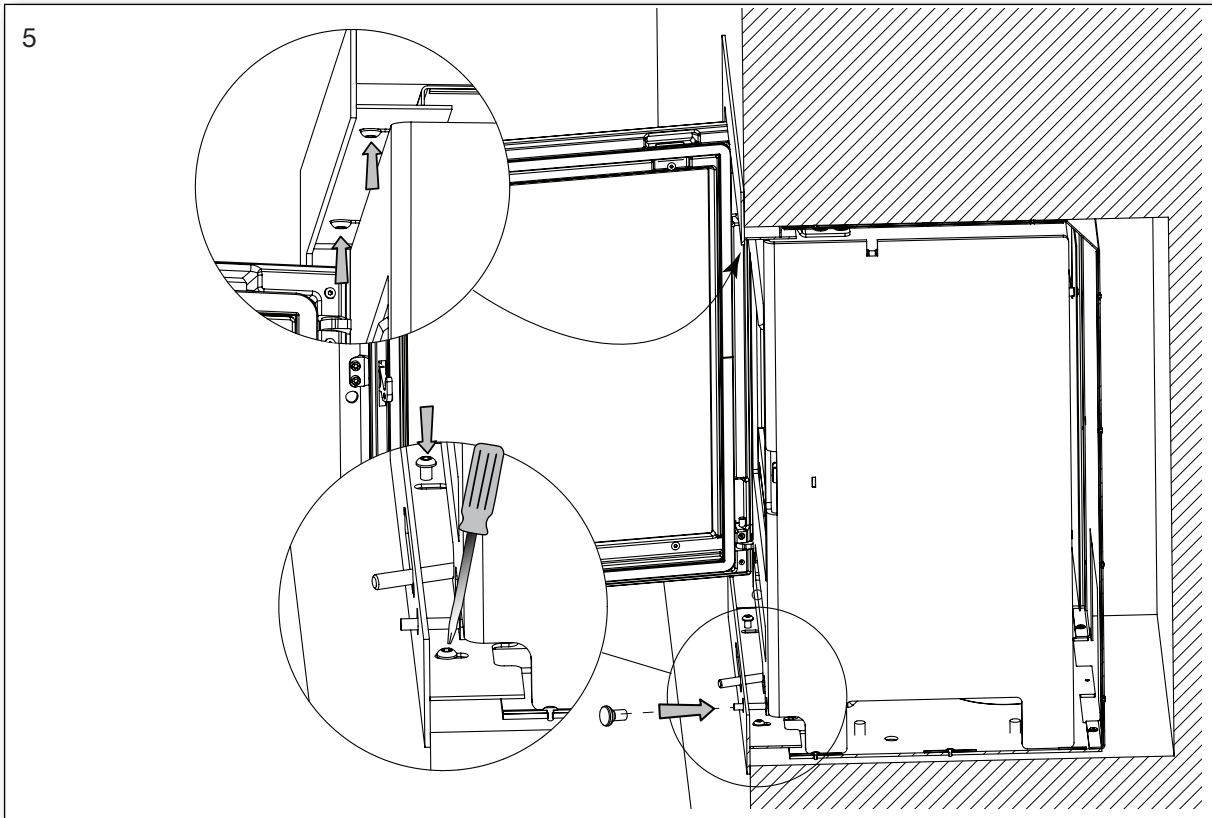

Classic floor model, flat floor- and wall model:

The frame front must be flush with the front of the door. Hidden wall model. See fig. 6.

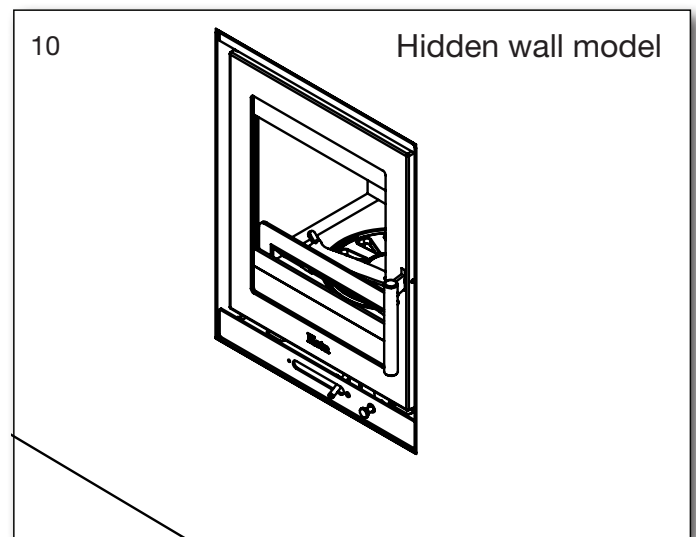
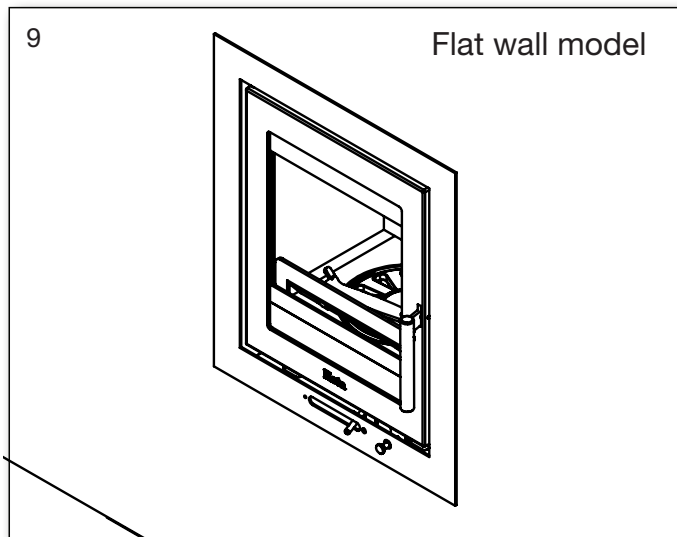
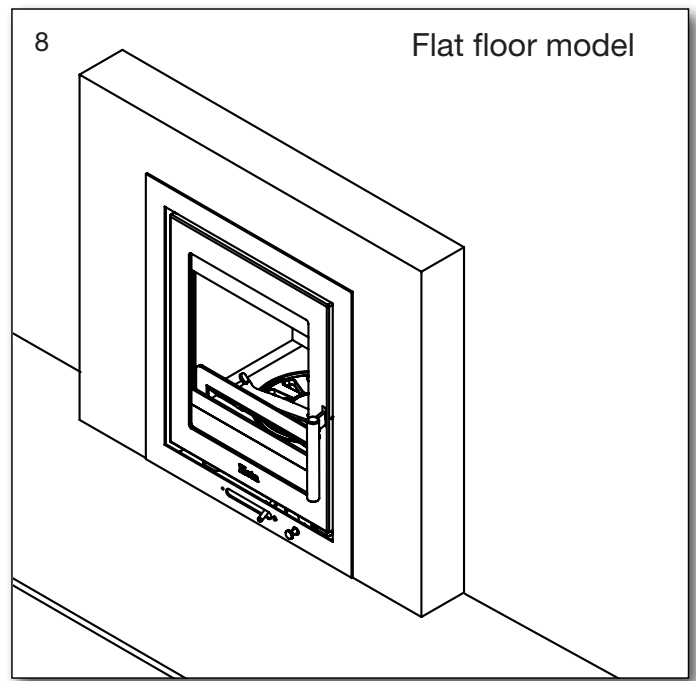
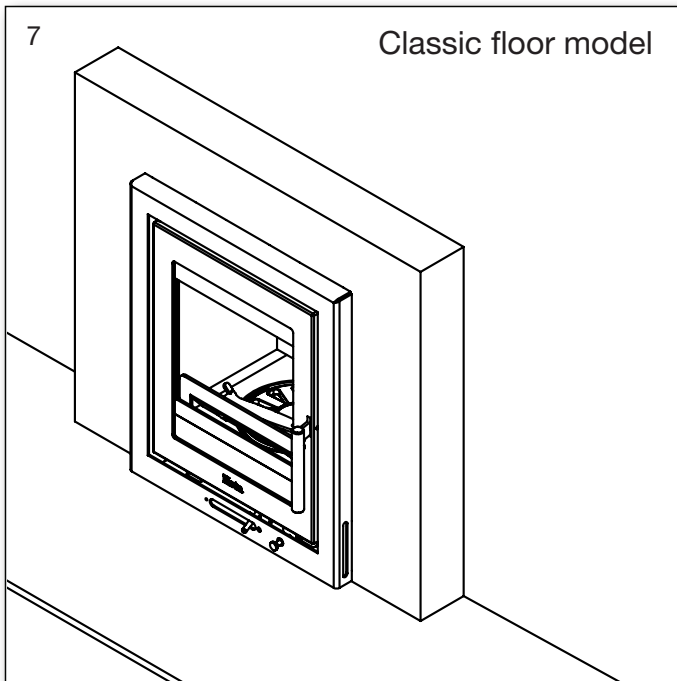

3. Connecting external air supply from behind

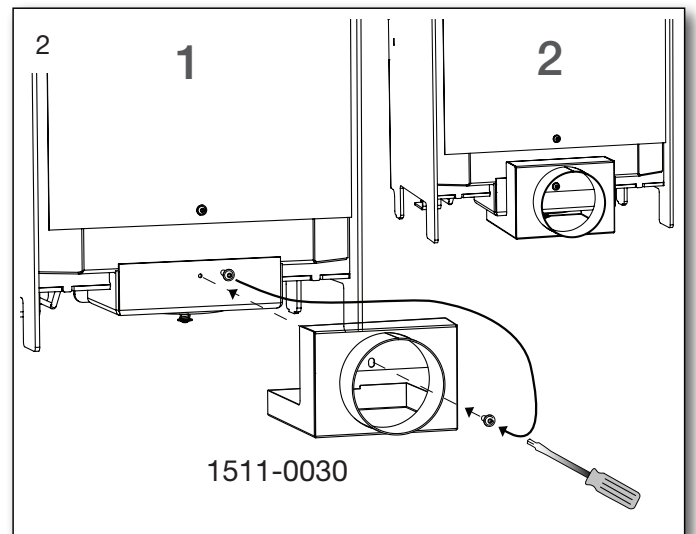
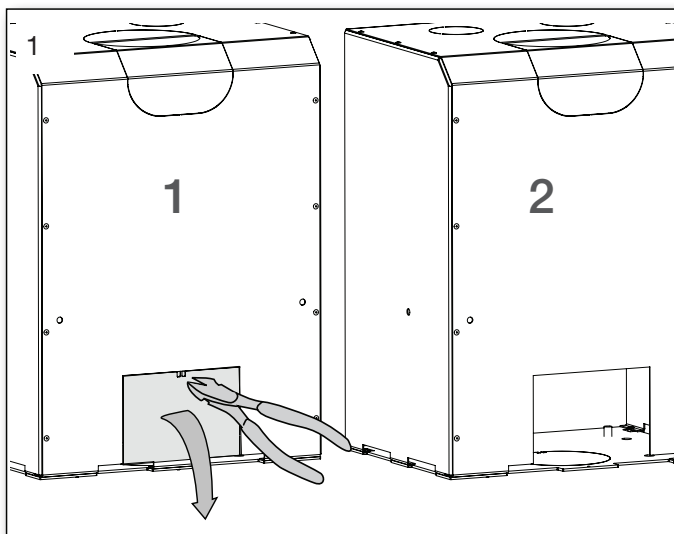

If rear outdoor air connection purchased, 1511-0030 must be installed before inserting the stove.

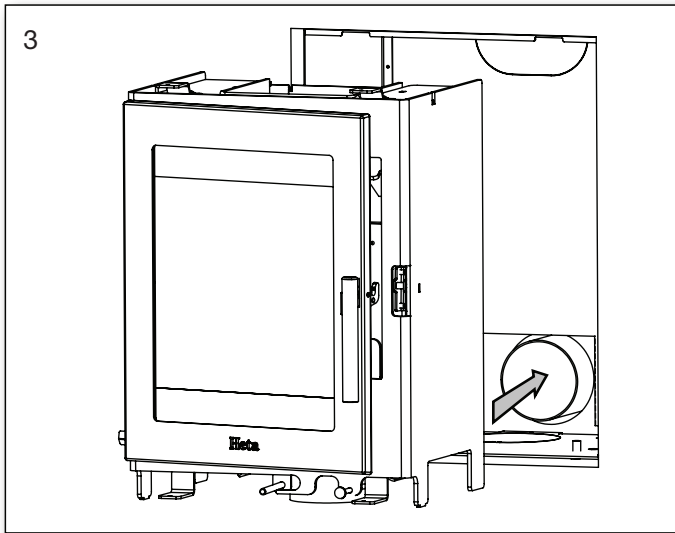

4. Connecting external air supply from below

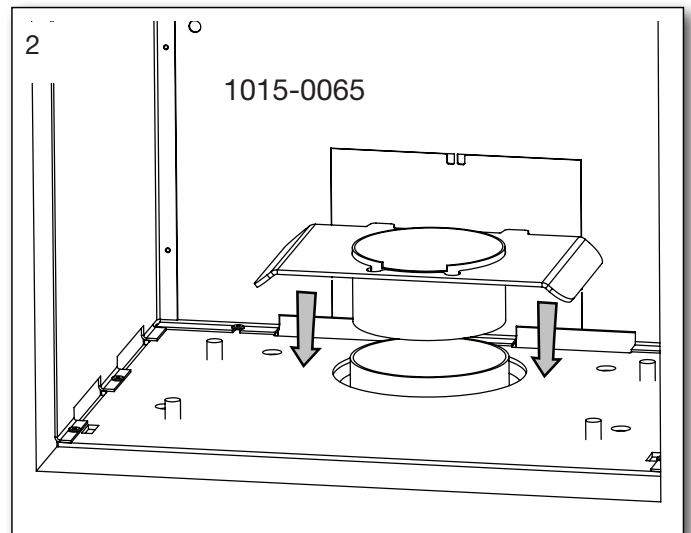
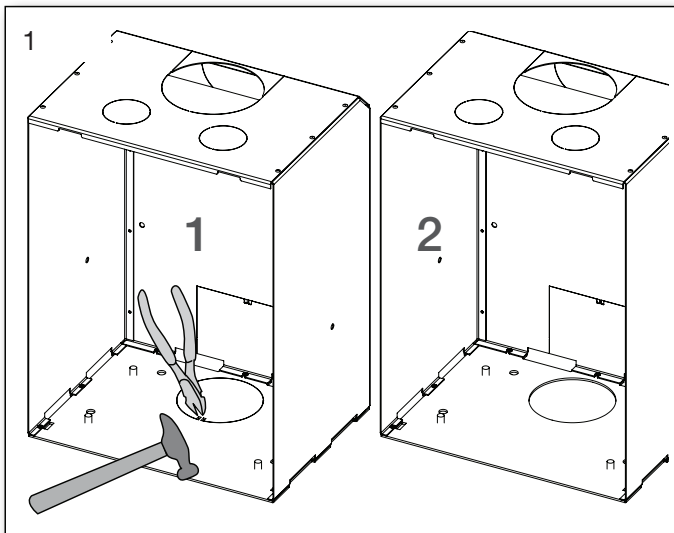

If below outdoor air connection purchased, 1015-0065 must be installed before inserting the stove.

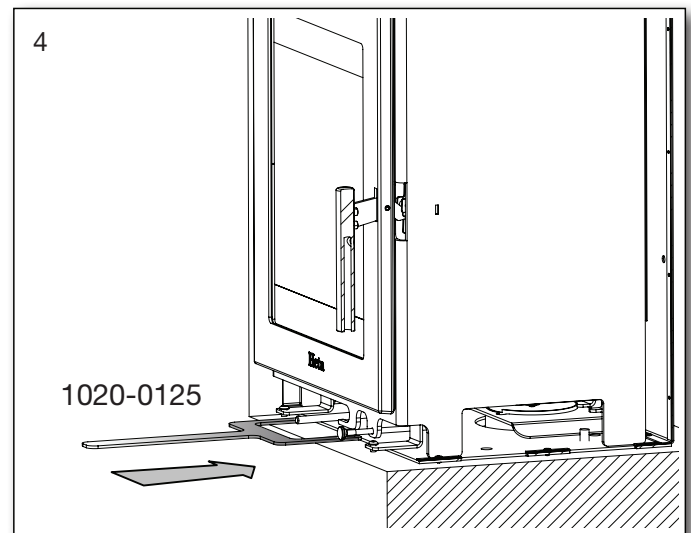
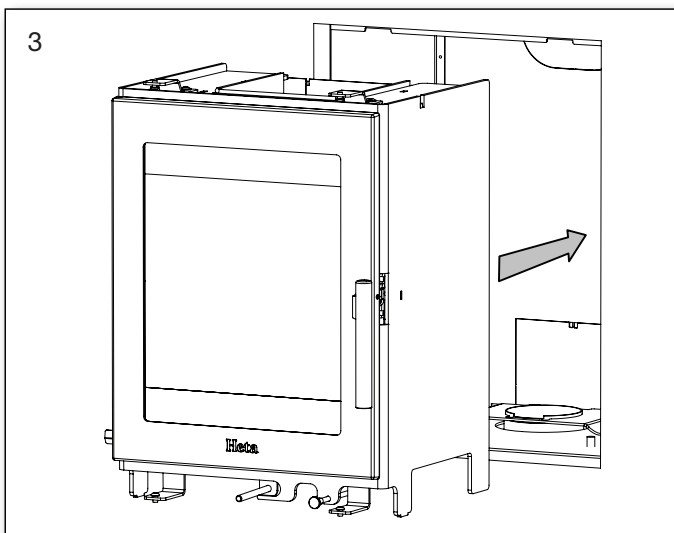

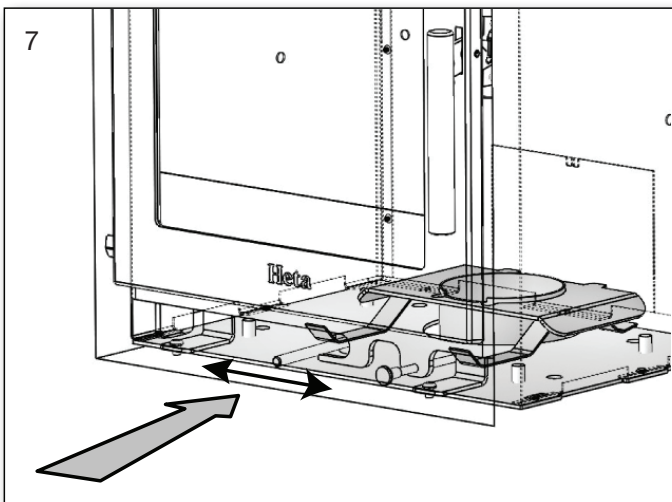
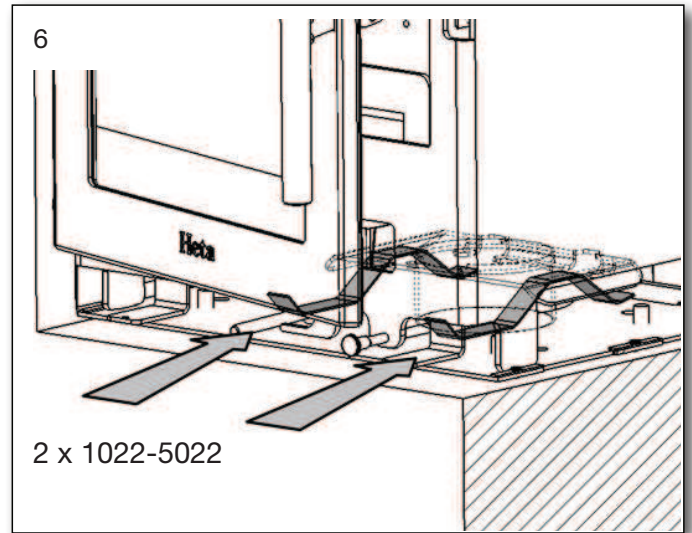
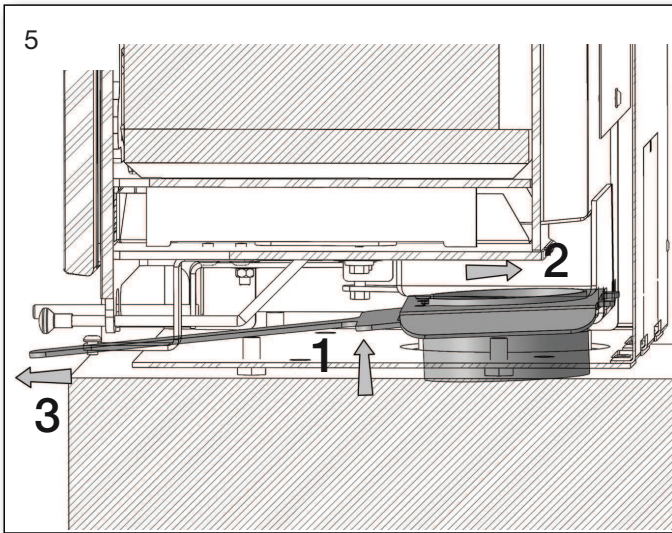

Check that the air regulator moves freely.

5. Appendix A

The Clean Air Act 1993 and Smoke Control Areas Under the Clean Air Act local authorities may declare the whole or part of the district of the authority to be a smoke control area. It is an offence to emit smoke from a chimney of a building, from a furnace or from any fixed boiler if located in a designated smoke control area. It is also an offence to acquire an "unauthorised fuel" for use within a smoke control area unless it is used in an "exempt" appliance ("exempted" from the controls which generally apply in the smoke control area).

The Secretary of State for Environment, Food and Rural Affairs has powers under the Act to authorise smokeless fuels or exempt appliances for use in smoke control areas in England. In Scotland and Wales this power rests with Ministers in the devolved administrations for those countries. Separate legislation, the Clean Air (Northern Ireland) Order 1981, applies

in Northern Ireland. Therefore it is a requirement that fuels burnt or obtained for use in smoke control areas have been "authorised" in Regulations and that appliances used to burn solid fuel in those areas (other than "authorised" fuels) have been exempted by an Order made and signed by the Secretary of State or Minister in the devolved administrations.

The Inspire 40 have all been recommended as suitable for use in smoke control areas when burning dry wood logs.

Further information on the requirements of the Clean Air Act can be found here: <https://www.gov.uk/smoke-control-area-rules>

Your local authority is responsible for implementing the Clean Air Act 1993 including designation and supervision of smoke control areas and you can contact them for details of Clean Air Act requirements.



Ecodesign
EU Declaration of Conformity

DoC Inspire 40 Insert 2215-2016

Product fiche



Manufacturer	Heta A/S
Address	Jupitervej 22, DK 7620 Lemvig
E-mail	heta@heta.dk
Website	www.heta.dk
Telephone	+45 9663 0600

Model identifier	Inspire 40 Insert
-------------------------	-------------------

The identified product described above is in conformity with:

The relevant EU harmonized regulations:

DIR 2009/125/EF

REG (EU) 2015/1185

REG (EU) 2015/1186

REG (EU) 2017/1369

REG (EU) 305/2011

The relevant harmonized standards

EN 13229:2001/A1:2003/A2:2004

CEN/TS 15883:2010

Notified body relevant to the assessment and verification of constancy of performance

Danish Technological Institute, DK-8000 Aarhus
No. 1235. Report no. 300-ELAB-2215-EN

Characteristics when operating with the preferred fuel only

Heat output

Item	Symbol	Value/Unit
Nominal heat output	P_{nom}	4 kW
Minimum heat output	P_{min}	

Useful efficiency (NCV as received)

Useful efficiency at nominal heat output	$\eta_{th, nom}$	84%
Useful efficiency at minimum heat output	$\eta_{th, min}$	

Auxiliary electricity consumption

At nominal heat output	$e_{l, max}$	- kW
At minimum heat output	$e_{l, min}$	- kW
In standby mode	$e_{l, SB}$	- kW

Type of heat output/room temperature control

single stage heat output, no room temperature control	Yes
two or more manual stages, no room temperature control	No
with electronic room temperature control	No
with electronic room temperature control	No
with electronic room temperature control plus day timer	No
with electronic room temperature control plus week timer	No

Other control options

room temperature control, with presence detection	No
room temperature control, with open window detection	No
with distance control option	No

Fuel	Preferred fuel	Other suitable fuel
Wood logs with moisture content ≤ 25 %	Yes	No
Compressed wood with moisture content < 12 %	No	No
Other woody biomass	No	No
Non-woody biomass	No	No
Anthracite and dry steam coal	No	No
Hard coke	No	No
Low temperature coke	No	No
Bituminous coal	No	No
Lignite briquettes	No	No
Peat briquettes	No	No
Blended fossil fuel briquettes	No	No
Blended biomass and fossil fuel briquettes	No	No
Other blend of biomass and solid fuel	No	No

Emissions at nominal heat output	η_s %	mg/Nm ³ (13 % O ₂)			
		PM	OGC	CO	NO _x
	≥ 65	≤ 40	≤ 120	≤ 1500	≤ 200
74	9	52	677	108	

Technical documentation

Indirect heating functionality:	No
Direct heat output:	4 kW
Energy Efficiency Index (EEI):	EEI 112
Fluegas temperature at nominal heat output	T 215°C
Energy efficiency class	

Safety

Reaction to fire	A1
Test of fire safety in connection with the burning of wood	Approved
Distance to combustible materials Rear. With insulation	Minimum distances in mm #
Sides distance to combustible materials	#
Furniture distance	900

See Clearances for installation in instructions

Signed on behalf the manufacturer of 04.05.2022

The chimney sweep's signature Date _____

Heta A/s
JUPITERVEJ 22 · DK-7620 LEMVIG
TLF. +45 9663 0600 · FAX +45 9663 0616
Martin Bach

Signature _____

